

***Thank you very much for
purchasing RAP intelligent
vehicle.***

It is our responsibility to provide you with high safety products. In addition, in order to enable you to get familiar with the functions of the vehicle more quickly and ensure safe and comfortable driving, we have compiled this manual.

This manual clearly introduces the knowledge of safe driving and vehicle functions as a guide for your safe driving. But in actual driving, you also need to use and adjust it according to the actual situation.

All the data and specifications in this manual are up-to-date until the manual is printed. As the company will continue to upgrade and redesign the vehicle, the equipment and performance of the subsequent models will be subject to change without notice.

We believe that this manual will give you the correct guidance for your driving, and also hope that you will attach this manual when you transfer your vehicle.

ZHEJIANG RAP INTELLIGENT VEHICLE CO., LTD

Notes to users

In this manual, you will see warnings about personal safety or possible damage to the vehicle. Please follow the instructions in the warnings when operating the vehicle to avoid personal injury or damage to the vehicle.

Unless otherwise stated, the instructions in this manual regarding the vehicle orientation (front, rear, left and right) are subject to the driving direction of the vehicle.

The warning types, layouts and methods of use in this manual are as follows:

⚠ Danger

Be alert to high risks and ignoring such information could be life-threatening.

⚠ Warning

Be alert to moderate risks and ignoring such information may lead to injury.

ℹ Note

Pay attention to minor hazards and ignoring such information may cause vehicle damage.

♻ Environmental protection

Environmental protection instructions.

Arrow indication operating

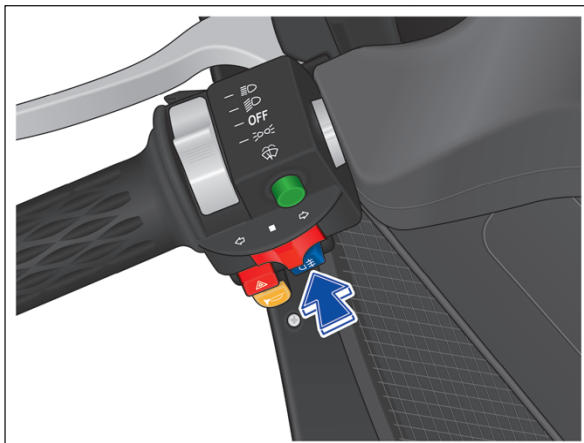

Indicates the direction of operation (e. g. pushing upward, pulling downward, turning left, moving right, shaking back and forth, etc.).

Introduction..... 1
 Notes to users 2

1 Charging Device

Charging instructions 6
 Charging precautions 6
 On-board charging device 7
 Charging method 9
 Household single-phase
 AC charging..... 9
 Charging pile single-phase
 AC charging..... 10
 Battery 12
 Power battery 12

2 Operation Guide

Instrumentation 16
 Combination meter view 16
 SOC electricity meter 17
 Voltage display 17
 Current display 17
 Tachometer..... 17
 Speedometer 17
 Mileage display 18
 Gear display 18
 Clock display 19
 Combination meter indicator
 / warning light 19

Driving computer 21
 Keys and doors..... 25
 Mechanical key..... 25
 Anti-theft system..... 25
 Wiper and light..... 27
 Wiper switch 27
 Light distribution view 28
 Light switch..... 30
 Seat 33
 Seat cushion..... 33
 Backrest 33
 Driving aid..... 34
 Rearview mirror 34
 Rearview radar 34
 Reversing image 36
 Swing system 37
 Storage device..... 38
 Storage box under the seat 38
 File bag..... 38
 Other devices 39
 Storage hook..... 39
 USB interface 39
 12V power supply 40

3 Driving Guide

Preparation 42
 Run-in period..... 42
 Preparation before driving 42
 Directional handle..... 43

Charging device
 Operation guide
 Driving guide
 Maintenance
 Emergency treatment
 Technical data

Horn.....	44	Reflective vest.....	63
RAP sound simulation	44	Basic hand tools	64
Start driving	45	Contingency processing	65
Ignition switch.....	45	Unable to start.....	65
Shifting system	46	If the vehicle is trapped	65
Manual brake.....	47	Vehicle traction.....	66
Parking brake	47	Tire burst	67
Starting vehicle	48	Fire emergency processing	
Starting.....	48	plan.....	68
Parking	48	High pressure component	70
Driving and environment....	50	Fuse	71
Driving essentials	50		
Drive in special weather	50		

4 Maintenance

Daily maintenance	54
Vehicle corrosion	
protection.....	54
Vehicle cleaning	55
Additional maintenance	57
Brake fluid	57
Cleaning solution.....	58
Tire	59

5 Emergency treatment

Important information.....	62
Hazard warning lamp	62
Triangular warning board.....	62

6 Technical data

Information.....	76
Vehicle parameters.....	76
Prompting message.....	79
Vehicle identification	
code.....	79
Nameplate of entire	
vehicle	79
Motor model and serial	
number	80
Warning sticker.....	80



TIRE NOTE
Pressure: Front 250kPa (2.5kgf/cm)
Rear 250kPa (2.5kgf/cm)
Type: Front 110/90 R12
Rear 110/90 R12

1 *Charging device*

This chapter will introduce information on charging methods and charging precautions to ensure that your vehicle has good maneuverability at all times.

Charging precautions

- ◆ Please charge with the dedicated charging device provided by RAP Intelligent Vehicle:
 - » Do not modify, disassemble or repair the charging device.
 - » Do not use extra wires or adapters to avoid the risk of fire or electric shock.
 - » Please stop charging immediately when the charging fails or there is an abnormality.
 - » Please do not use the charging device when the protective package is cracked or any damage is revealed.
 - » Do not allow minors to touch or use charging devices, and do not let minors approach during use.
 - » Please do not pull the cable directly to move the charging device. When you move it, please handle it gently.
- ◆ Please choose to charge in a relatively safe environment (such as avoiding liquids, fire sources, etc.).
- ◆ The arc may occur during charging. Do not expose to flammable gases and keep them ventilated to avoid danger.
- ◆ If the vehicle needs to be parked for a long time without using, please charge the vehicle first.
- ◆ When charging, please make sure that the charging plug is in good contact with the charging socket, otherwise it will lead to safety accidents.
- ◆ Before starting the vehicle, please make sure that the charging device has been disconnected and the charging port cover has been closed.
- ◆ If you need to travel on a rainy day while your vehicle is running low and needs to be charged, we advise you to properly operate according to the following requirements when using outdoor charging devices:
 - » Choose a higher location to park and recharge to prevent the battery from soaking in the water.

- » When charging, the water near the charging port should be cleaned to prevent the water from entering the charging port. When plugging or unplugging the charging connector, be sure to cover it with rainproof equipment to prevent rainwater from splashing into the charging connector and charging port.
- » Check and remove any water and stains that may exist in the charging connector plug.

Warning

Please ensure that the charging interface is dry and free of foreign matter before charging. Otherwise, it may cause short circuit or electric shock or even cause fire during charging, which may cause serious personal injury or property damage.

To avoid serious personal injury, do not touch the charging terminal or the metal terminal inside the charging connector while the vehicle is charging.

Do not use wet hand to plug or remove the plug, otherwise it may cause electric shock and personal injury.

On-board charging device

- 1** Power plug
- 2** Charging cable
- 3** Charging connection plug
- 4** Control box

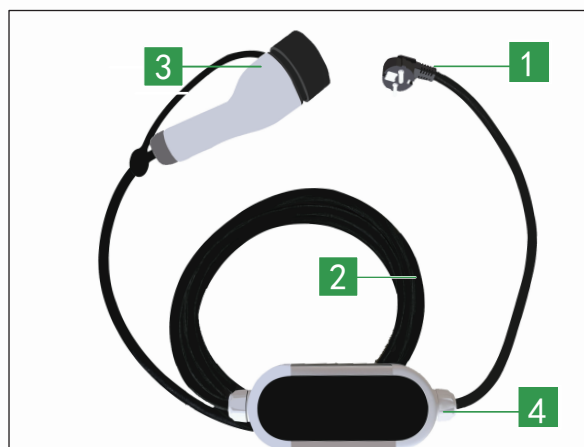

i Note

Do not use the charging device in the sun or in a closed environment.
Do not modify the charging device without permission, otherwise it will be prone to danger.
Please wait for the vehicle to enter the normal charging state before leaving.

Household single-phase AC charging

i Note

When using household single-phase AC charging, use a special socket with safety protection devices such as leakage protection devices and air switches, and avoid sharing the line with other household appliances.

The household single-phase AC charging method is as follows:

1. The ignition switch is in the "OFF" position.
2. Open the charging port cover and insert the charging connection plug.

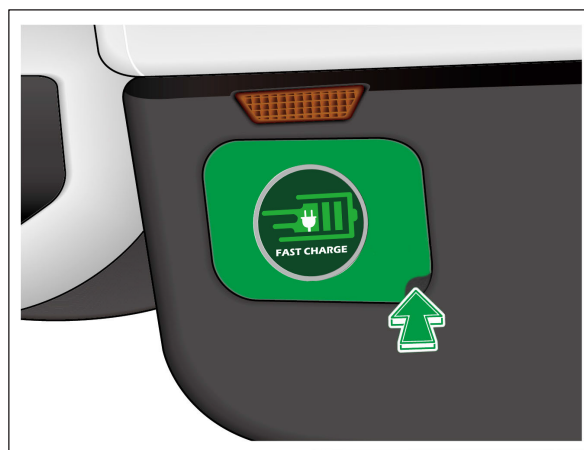

3. Connect the power plug at the power supply end, the power indicator light of the charging device control box is red, the connection indicator light is green, and the start indicator light flashes, indicating the start of charging.



4. The instrument lights up and shifts to the charging interface. At the same time, the meter screen shifts to the charging animation state.

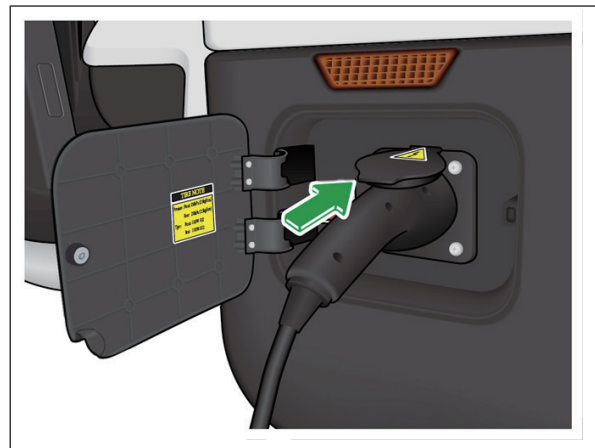

5. When charging is complete, unplug the charging connection plug.
6. Confirm that the dust cover of the charging port is properly closed and close the charging cover of the vehicle.
7. Disconnect the power plug of the power supply end, arrange the on-board charging device, and place it properly to complete charging.

Charging pile single-phase AC charging

Charging pile single-phase AC charging method is as follows:

1. Set the ignition switch to the "OFF" position.
2. Open the vehicle charging port cover.
3. Open charging port dust cover.
4. Connect the charging connection plug with the charging port, set the charging pile parameters, and start charging according to the setting of charging pile (such as swiping card).
5. The instrument lights up the charging connection indicator, and the electricity meter is switched to the charging animation state.
6. When charging is complete, unplug the charging plug.

7. Confirm that the dust cover of the charging port is properly closed and close the charging port cover of the vehicle.
8. Disconnect the power plug of the power supply end, arrange the charging device, and place it properly to complete charging.

**i Note**

The above charging method is a general charging method, which may be slightly different from the actual charging method introduced by the charging pile. Please use the method prompted by the charging pile for actual charging.

Please select type 2 of charging station to charge fast charge vehicle (rated voltage 220 V, rated current 32 A).

Power battery

- ◆ The main power source of the RAP intelligent vehicle is the power battery, which can be recharged repeatedly. However, when the power battery is less than 10%, it needs to be charged as soon as possible to prolong the battery life.
- ◆ For new vehicles, when the power battery is in a normal state, due to different driving habits (such as frequent acceleration and deceleration), road conditions (such as long-term climbing) and temperature (such as low temperature), the endurance mileage of the vehicle will be properly reduced, which is a normal phenomenon.
- ◆ The time required for the completion of the power battery charging is affected by the charging power, remaining battery capacity, battery temperature, vehicle use time and ambient temperature.
- ◆ In order to keep the power battery in an optimal state, please fully charge the power battery regularly.
- ◆ The battery should not be put on hold for a long time. It should be discharged and charged at least once a month. Otherwise, the service life of the battery will be greatly affected and the battery will be scrapped.
- ◆ The power battery is located under the chassis of the vehicle. When driving the vehicle, care should be taken to avoid hitting or flooding the power battery.
- ◆ The battery is a special chemical product that needs to be properly used and maintained. Daily operation of fully charging or discharging (only suitable for lead acid battery, lithium battery better be kept in medium power) is critical to its performance maintenance. At the same time, due to chemical characteristics, the phenomenon of natural attenuation of battery capacity exists. Therefore, the mileage may be reduced for vehicles that have been in use for some time.

⚠ Warning

The power battery is a high-voltage component. Non-factory personnel should not open or repair the power battery without permission.

♻ Environmental protection

The recovery of the power battery must be carried out by a qualified unit to avoid environmental pollution and injury to the operator.

Power battery recovery requirements and procedures

The power battery is a high-voltage component that is easy to cause environmental pollution. If it is improperly disassembled, it may cause electric shock injuries and environmental pollution. For the disposal of old and abandoned batteries, please contact the local dealer, we will handle according to the specified procedures.



2 Operation Guide

This chapter will introduce you to all the equipment related to driving safety and comfort, so that you can get familiar with your vehicle quickly to reduce the driving safety hazards.

Combination meter view

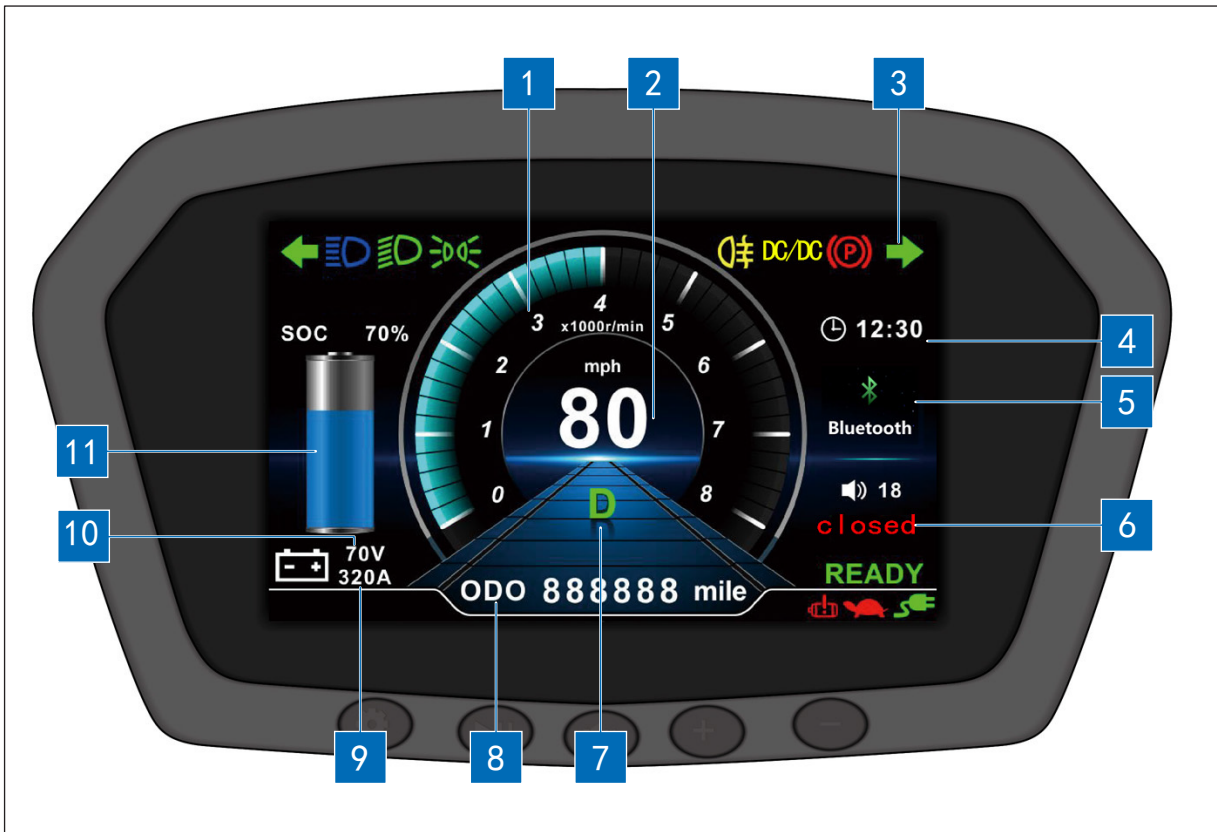

- | | | | |
|---|---------------------------------|----|-----------------------|
| 1 | Tachometer | 7 | Gear display |
| 2 | Speedometer | 8 | Mileage display |
| 3 | Indicator light / warning light | 9 | Current display |
| 4 | Clock display | 10 | Voltage display |
| 5 | Multimedia display interface | 11 | SOC electricity meter |
| 6 | Multimedia status | | |

SOC electricity meter

- ◆ The SOC electricity meter displays the current battery level.
- ◆ The display range of the SOC electricity meter is 0 ~ 100% and its display refreshes once every 10s. The digital and columnar double display battery capacity. When SOC is between 0 and 10%, the columnar display is red, and the voice indicates "low battery capacity". When SOC is between 11% and 100%, the columnar display is blue.

Voltage display

- ◆ Used to display the real-time voltage of the battery in V (volts).
- ◆ The voltage display range is from 0 to 999V, real-time display.

Current display

- ◆ Used to display the real-time current of the battery in A (ampere).
- ◆ The current display range is from 0 to 320A, real-time display.
The charging current is negative and the discharge current is positive.

Tachometer

- ◆ The tachometer is used to display the real-time speed of the motor in r/min (rotation per minute).
- ◆ The display range of the tachometer is 0 ~ 8000r/min.

Speedometer

- ◆ The speedometer is used to display the current speed of the vehicle in

km/h (kilometers per hour).

- ◆ The display range is 0~99km/h, the speed unit and speed limit can be set in the menu. When the speed is invalid, the normal color (white) figure shows the speed is 0. When the speed is effective, the normal color figure displays the speed; when the vehicle speed indication is greater than or equal to the speed alarm setting value, the digital display speed becomes red; At the same time, the speed is too high.

Mileage display

ODO

- ◆ Shows the total number of miles traveled by the vehicle.
- ◆ The display range of ODO is 0~999999km. When the total mileage exceeds the maximum display value, the total odometer stops accumulating and the display stays at the maximum display value.

Trip

- ◆ The trip shows the total mileage traveled since the last trip reset.
- ◆ The trip display range is 0~999.9km. When the maximum display value is exceeded, it will be automatically cleared and accumulated and displayed from 0.

Mileage display switching and clearing

- ◆ Short press the set button to switch between the ODO and the trip interface.
- ◆ Trip clearing: trip interface, long press the set button for 3s.

Gear display













- ◆ Display the gear information in the current state, such as N/D/R.
- ◆ When in "R" gear position, if the vehicle is provided with reverse image

and sensor, the information of reverse image and sensor will be displayed by the instrument first.

Clock display

- ◆ It is used to display the current time, the clock can be set in the menu settings.

Combination meter indicator / warning light

 Left/right turn indicator	 Position light indicator
 High beam indicator	 Rear fog light indicator
 Low beam indicator	 Charging connection indicator
 READY indicator	 Motor fault indicator
 Low battery indicator	 Power limit indicator
 Parking brake indicator	 DC/DC indicator

Left / right turn indicator

- ◆ When the turn light is turned on, the turn light and the turning indicator on the corresponding side flashes at the same time; When the turn light is turned off, the turn light and the turning indicator on the corresponding

side are extinguished simultaneously.

- ◆ Turn on the hazard warning light switch, all the turn signals and the turn indicators flash at the same time; Turn off the hazard warning light switch, all the turn signals and the turn indicators go out simultaneously.

High beam indicator

- ◆ Turn the ignition switch to the “ON” position to turn on the high beam, and the high beam indicator lights up.
- ◆ Turn off the high beam and the high beam indicator is off.

Position light indicator

- ◆ The ignition switch is set to the “ON” position, the position light or low beam is turned on, and the position light indicator lights up.
- ◆ Turn off the position light and low beam light and the position light is off.

Rear fog light indicator

- ◆ The ignition switch is switched to “ON” position, the low beam or high beam lights up, turn on the rear fog light, and the rear fog light indicator is turned on.
- ◆ Turn off the rear fog light, and the rear fog light indicator goes out.

Low beam indicator

- ◆ Turn the ignition switch to the “ON” position, turn on the low beam, and the low beam indicator will light.
- ◆ Turn off the low beam and the low beam indicator is off.

READY indicator

- ◆ This indicator light reflects the vehicle starting state. When the ignition switch is turned to the “ON” position and the gear position is in the “D” or “R” position, the indicator lights up, indicating that the vehicle is ready, and the acceleration handle can be turned to drive.

Charging connection indicator

- ◆ The charging gun is connected to the charging port of the vehicle and the charging connection indicator light is on.

Low battery indicator 

◆ If this light is on, it indicates that the power battery is less than 25% and needs to be charged as soon as possible.

Motor fault indicator 

◆ If this light is on, it indicates that the motor system has failed. It is recommended to stop immediately and contact the authorized service station of RAP.

Power limit indicator 

◆ This indicator lights when the power battery is low and the motor power is limited.

Parking brake indicator 

◆ When the parking handle is pulled up, this indicator lights up to indicate that the vehicle has been parked.

DC/DC indicator 

◆ If this light is on, it means the DC/DC converter is not working. It is recommended to contact the RAP authorized service station immediately.

Setting of combination instrument

Backlight luminance

- ◆ When the ignition switch is set to “ON” position and the position light is not turned on, the brightness of the TFT screen backlight is the brightness level set in the menu.
- ◆ When the ignition switch is set to “ON” position, the brightness of the TFT screen backlight is reduced when the position light is turned on.

Instrument button

- 1** Setting button
- 2** Play pause button
Multimedia switch key
- 3** Mute button
Multimedia selection button
- 4** Volume up button

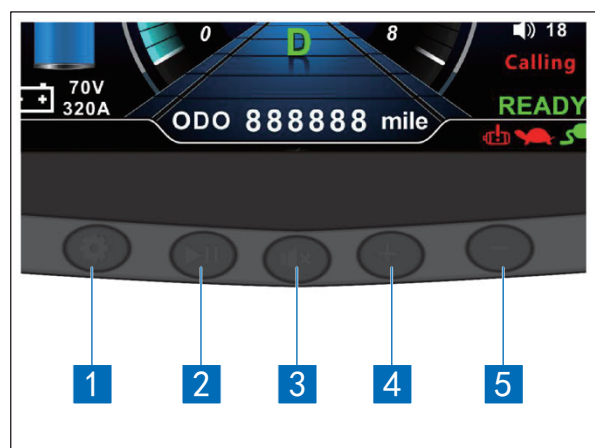

Previous button

5 Volume down button

Next button

Menu settings

In the ODO interface, press and hold the setting button for 3s to enter the menu setting interface. After entering, press the SET button shortly to select the menu setting options. Move to the last one and press the SET button again to exit the menu settings.

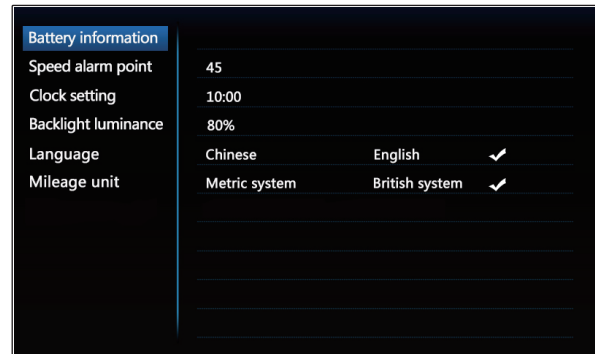

◆ Speed alarm setting

- » At the vehicle speed alarm point, press and hold for 3s, the alarm setting speed starts to flash, short press plus 1, press 3s again to save. The setting range is 10~140 cycles, and the default number is 45.

◆ Clock settings

- » When the clock is in setting, press and hold for 3s, the hour digit flashes, short press plus 1, jump to minute digit flash if no operation in 3s, long press 3s to save. The hour range is 0~23, the minute range is 0~59, and the default number is 10:00.

◆ Backlight setting



- » Automatically adjust the backlight brightness. When the ambient brightness is 10 ± 1 lm (lumen), the instrument brightness will automatically switch to the night mode.

◆ Language setting

- » In the language setting, long press 3s, Chinese flashes, short press English flash, press and hold 3s again to save. The range is Chinese and English, and the default is English.

Multimedia



1. Press and hold the multimedia key to open the multimedia, press and hold the multimedia key again, and the multimedia is closed.
2. When opening multimedia, the default state is the last shutdown.
3. When the multimedia is turned on, short press the multimedia switch key to pause or play.
4. When the multimedia is off, the minus key, plus key, and mute key are invalid.
5. Short press the multimedia selection button to switch between music  , movies  , and Bluetooth music  .
6. When playing multimedia, press and hold the plus/minus button to continuously increase/decrease the volume, and the volume range is 0~30.
7. When playing multimedia, short press the plus/minus button to close/receive the station.
8. Press and hold the mute button to mute the multimedia; press and hold the mute button again to cancel the mute and restore the volume.
9. When there are other voice prompts, multimedia will automatically mute; after other voice prompts are withdrawn, multimedia will automatically restore the volume.

Charging interface

◆ Charging connection

- » When charging is connected, the charging connection symbol is displayed and the charging connection screen is automatically displayed.

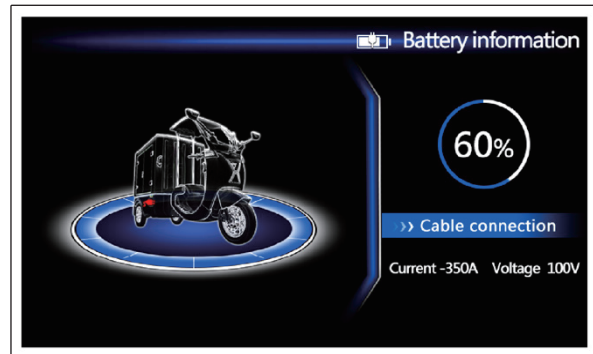

◆ Charging

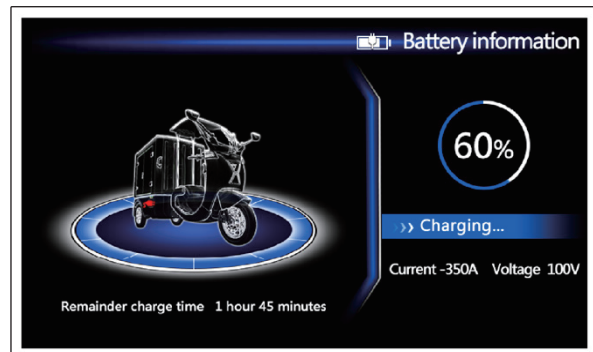

◆ Charging is full

- » The charging completion screen is displayed when the SOC meter is 100%.

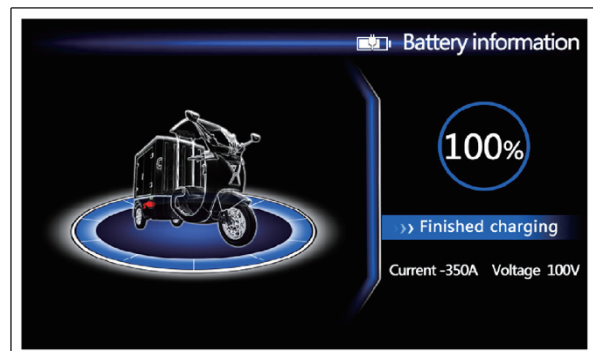

◆ Charging system failure

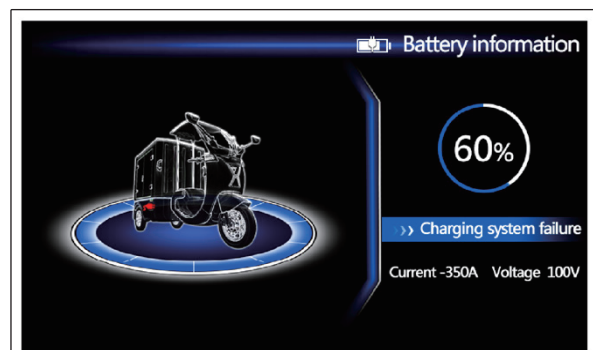

Mechanical key

- ◆ The mechanical key can be used to start the vehicle.



Anti-theft system

- ◆ The anti-theft system is designed to protect the vehicle from theft. The vehicle is equipped with vibration sensor. If the “LOCK” key is pressed after the vehicle is powered off and locked, the vibration of vehicle will activate the alarm, resulting in flashing of turn lamps and beeping of horn.

- ◆ Anti-theft remote control button

- 1 LOCK button
- 2 UNLOCK button
- 3 Vehicle search button

- ◆ Removal of fortification :

- » Press the UNLOCK button on the remote control to exit the burglar alarm, if it is in the alarm state, stop the alarm.
- » High voltage (received “READY” signal), if it is in the alarm state, stop the alarm and exit the burglary.

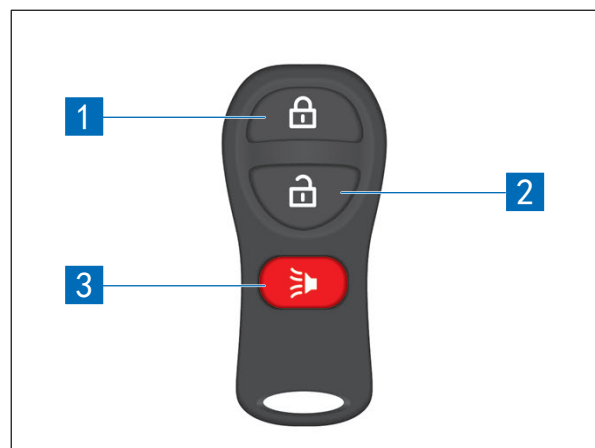

i Note

Please confirm that the vehicle enters the anti-theft state before leaving the vehicle.

◆ Car search function

- » When the vehicle is in anti-theft state, press the search button, the turn signal flashes and the horn whistles. Use this feature to find the specific location of the vehicle when the location of the vehicle cannot be confirmed.

Wiper switch

- ◆ When the ignition switch is in the “ON” position, the windscreen wiper and washer can work.
- ◆ The wiper switch can be turned upward from initial position"•"to wiping position .

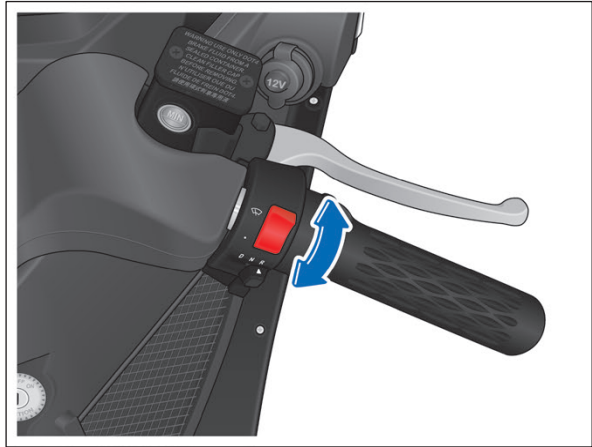

- ◆ When the ignition switch is in the “ON” position, press the windshield washer button and the windshield washer starts to spray water while the wiper starts working.

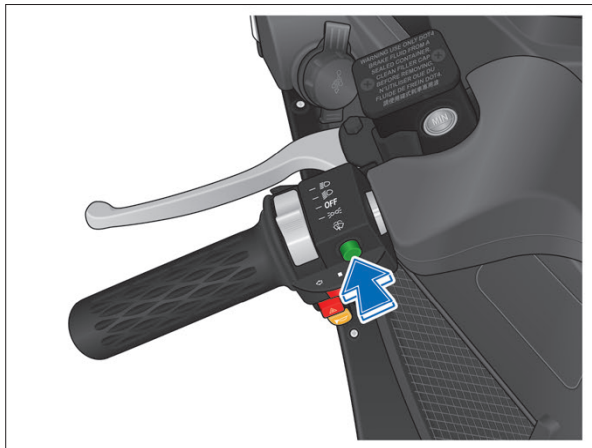

Operation guide

i Note

If the windshield is frozen, remove the ice and snow from the wiper arm before using the wiper.

Headlight distribution view



- | | | | |
|---|---|---|----------------|
| 1 | Turn signal | 4 | High beam |
| 2 | Low beam light | 5 | Retroreflector |
| 3 | Daytime running light /
position light | | |



- | | |
|------------------------------|-------------------------|
| 1 High brake lights | 5 Rear fog light |
| 2 License plate light | 6 Position light |
| 3 Turn signal | 7 Brake light |
| 4 Reversing light | 8 Retroreflector |

Light switch

- ◆ The ignition switch is in the “ON” position, and the light switch adjustment button is toggled from top to bottom:

- » : High beam position
- » : Low beam position
- » : OFF position
- » : Position light position

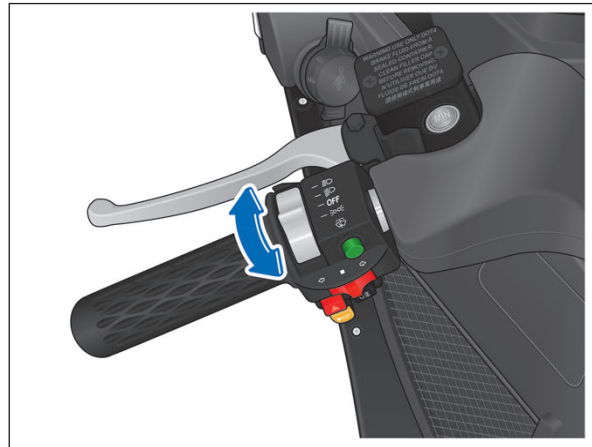

Note

Do not use the high beam when meeting other vehicles. The high beam that is turned on will be dazzling and can cause accidents easily.
Do not use the high beam when turning.

Turn signal

- ◆ The ignition switch is in the “ON” position, and the turn signal adjustment button is toggled from left to right:

- » : Left turn position
- » : Initial position, turn signal turns off.
- » : Right turn position

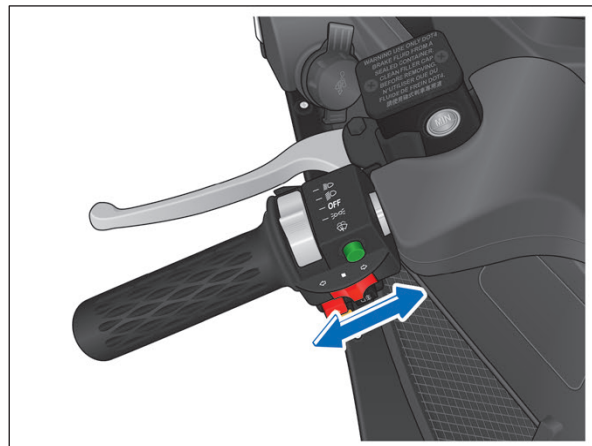

Rear fog light

- ◆ When the ignition switch is in the “ON” position, the low beam or high beam lights up, press the rear fog light switch, and the rear fog light lights up.

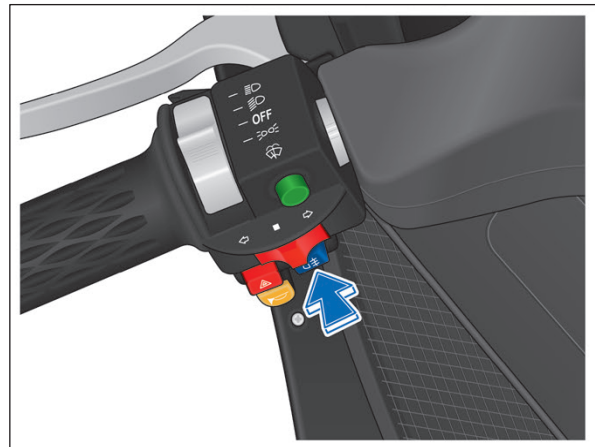

Note

The vehicle fog lights, the sides of the vehicle and the rear lights are equipped with retro reflectors to reflect the rear vehicles.

Daytime running light

- ◆ When the ignition switch is in the “ON” , the daytime running lamp will light on.

Brake light

- ◆ Hold the brake handbrake and the brake light and high brake light are on.

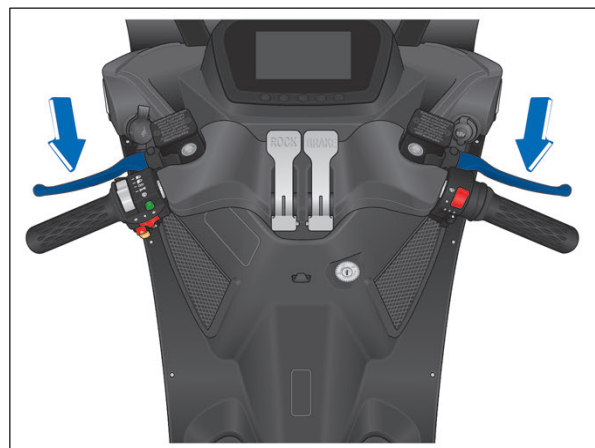

Reversing light

- ◆ When the ignition switch is in "ON" position, push the gear to "R" position, and the reversing light will light up.
- ◆ Exit the reverse gear and the reverse light goes out.

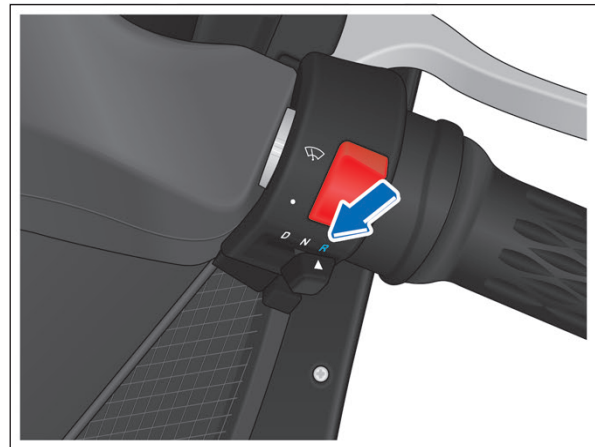

Overtaking signal

- ◆ When the ignition switch is in the "ON" position, press the overtaking signal switch, the high beam light will be on, and the vehicle meeting signal and overtaking signal will be sent out.

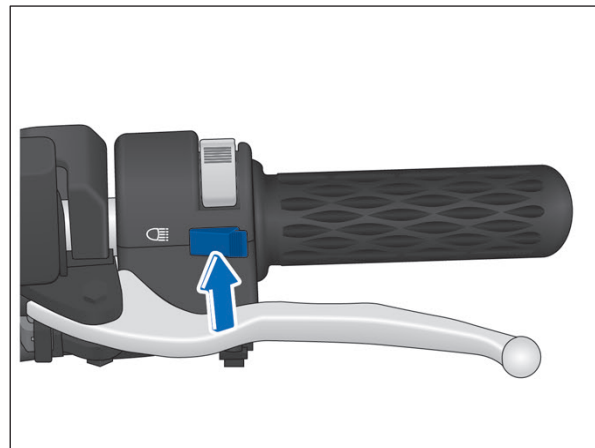

Seat cushion

- ◆ After the storage box under the seat is opened, make sure that the seat cushion is firmly locked to avoid affecting the use during driving.

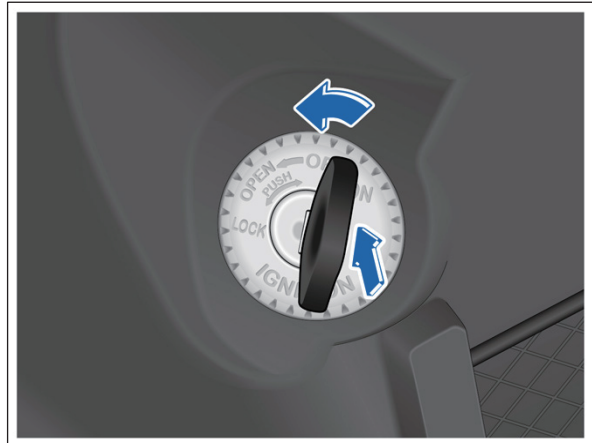
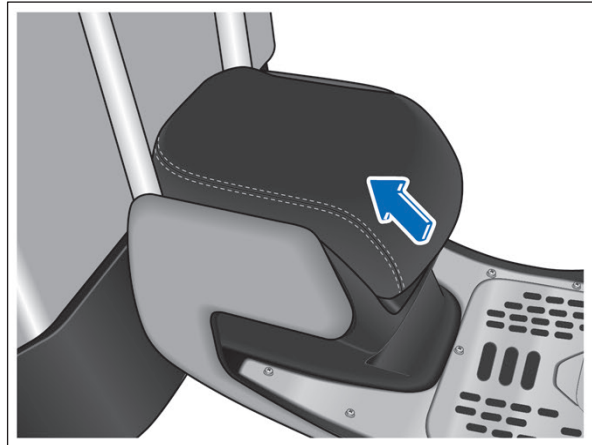

Backrest

- ◆ The height of the backrest can be adjusted according to the size of the driver. Move the 4 backrest adjustment locks so that the backrest can move up and down along the guide bar, and then tighten the 4 backrest adjustment locks when in the appropriate position. After the adjustment is complete, move the backrest up and down again to make sure the backrest is securely locked.

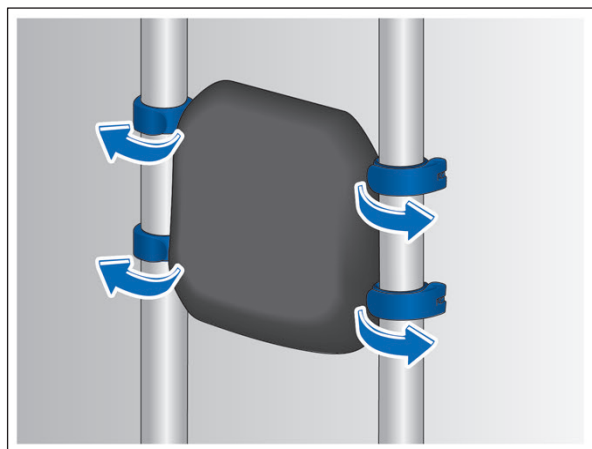

Rearview mirror

- ◆ Before driving the vehicle, be sure to adjust the angle of the mirror so that you can see the side of the car.
- ◆ Move the edge of the mirror body by hand to rotate the mirror around the center to adjust it to the proper position.

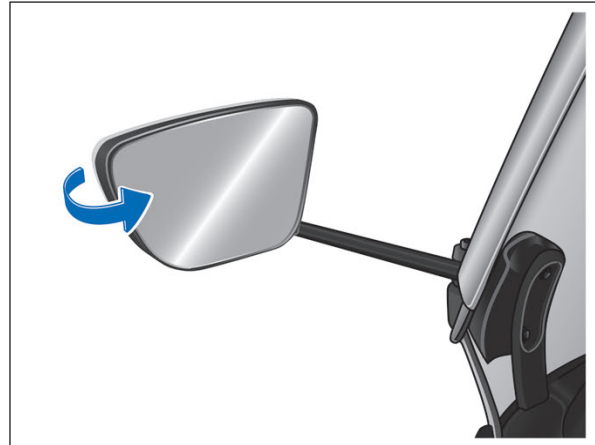

⚠ Warning

Please do not adjust the position of the rearview mirror during driving. Otherwise, it may lead to error of control and accident, resulting in serious casualties.

Reversing radar

- ◆ Reversing radar is a radar detection device installed on the rear bumper of the vehicle. During reversing and parking, the radar probe is used to detect whether there is any obstacle behind the vehicle. At the same time, the buzzer on the reversing radar main unit is driven to alarm at a certain frequency to remind the driver to park safely and avoid collision.
- ◆ When the gear is pushed to the “R” position, the controller will beep once to indicate that it hangs in the reverse gear, and the parking radar system will enter the working state. Exiting the “R” gear and the

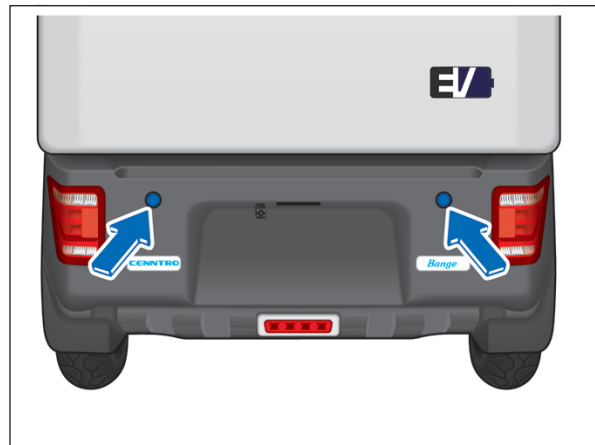

reversing radar stops working.

Obstacle detection and alarm function

- ◆ When the obstacle approaches probe from the 150cm outward, the reversing radar controller will alarm according to the distance of the obstacle. The alarm mode is buzzer alarm, which is divided into the following:

Obstacle distance from sensor (cm)	Buzzer frequency (Hz)
150~90	2
90~60	4
60~35	8
<35	Long alarming

***i* Note**

The system will be affected by factors such as the physical characteristics, the position of the object, angle, size, material or environment, which may lead to a narrower detection range, no alarm or false alarm.

Reversing radar is used to assist the driver in parking and reversing, and cannot replace your personal judgment. Be sure to operate the vehicle on an observation basis and do not rely solely on the parking radar system.

It is necessary to keep the outer surface of the radar probe of the reversing warning device clean. If it is found that there is snow, water, frost, mud, dust, etc., it should be removed in time to avoid affecting the function.

Reversing image

- ◆ When the gear is pushed to the “R” position, namely the reverse gear is entered, the reversing camera at the rear of the vehicle will start to work.
- ◆ While the reversing camera is working, the combination meter displays the reversing image to facilitate the driver to grasp the situation behind the vehicle.
- ◆ When the vehicle exits the reverse gear, the reversing image system is automatically turned off.



Reversing image screen

- ◆ The two lines in the figure are the reverse safety line.
 - » Red: 1 grid, distance less than or equal to 0.5m
 - » Orange: 2 grids, distance greater than 0.5m but less than or equal to 1m
 - » Green: 3 grids, distance greater than 1m

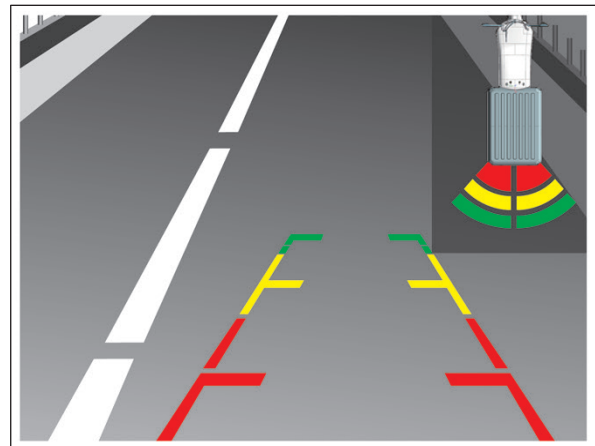

Note

Camera is used to assist the driver in parking and reversing, and cannot replace your personal judgment. Be sure to operate the vehicle on an observation basis and do not rely solely on the parking radar system. It is necessary to keep the outer surface of the reversing camera clean. If it is found that there is snow, water, frost, mud, dust, etc., it should be removed in time to avoid affecting the function.

Swing system

- ◆ The swing system can make the RAP intelligent vehicle reduce the turning radius when turning, reduce the risk of turnover when turning, keep balance when passing the rough road, improve the stability of the vehicle and improve the driving experience.

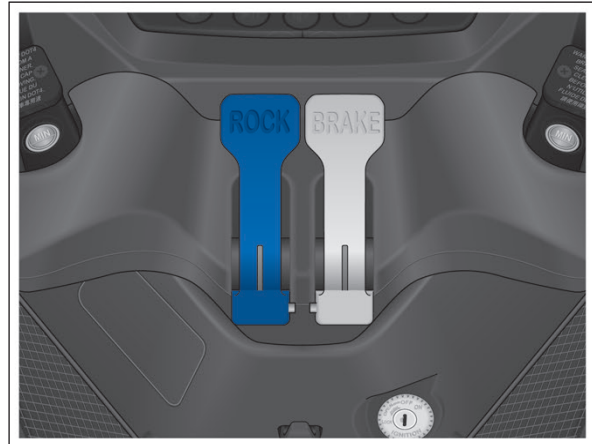

⚠ Warning

To help you know and learn the unique ROCK system and experience the fun of driving, please familiarize yourself with and master the driving skills of the vehicle in a safe place before driving on the road.

When the rock system is locked, the speed limit is 6km/h. When the rock system is unlocked, the speed limit is lifted.

For safety of you and the vehicle, do not make a sharp turn at high speed.

Locking ROCK handle when reversing makes it easier for you to control the vehicle.

Storage box under the seat

- ◆ Turn the ignition switch from the “OFF” position counterclockwise to the “OPEN” position, the storage box under the seat is unlocked and the seat cushion is pulled up to open the storage box under the seat.

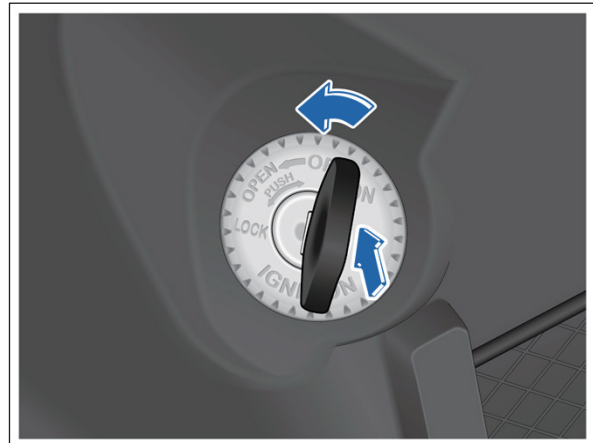
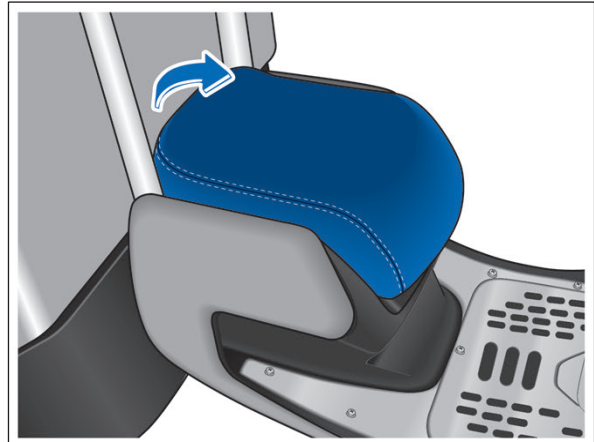

File bag

- ◆ There are file bags on the left and right sides under the handlebar, which can be used to store maps, magazines, newspapers, etc.

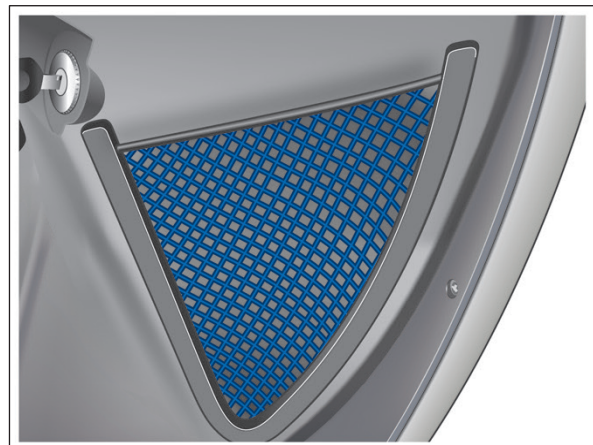

Storage hook

- ◆ The vehicle storage hook is located on the central control knee pad.



i Note

The maximum load capacity of the vehicle storage hook is 3kg, please use it reasonably.

USB interface

- ◆ This USB interface can be connected to multimedia.
- ◆ Insert the external memory into this USB interface, open the multimedia, and operate the multimedia button to play the files in the external memory.

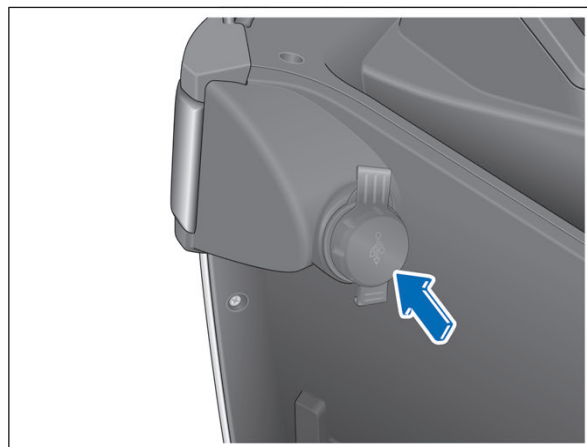

12V power supply

- ◆ 12V power supply can supply power to other powered devices.
- ◆ When using a 12V power supply, open the 12V power supply cover and the ignition switch must be in the “ON” position



i Note

Turn off the 12V power supply cover when not using a 12V power supply.

Do not insert other objects into the 12V power supply except the adapter plug, and prevent any liquid from entering the socket, otherwise it may cause electrical failure.

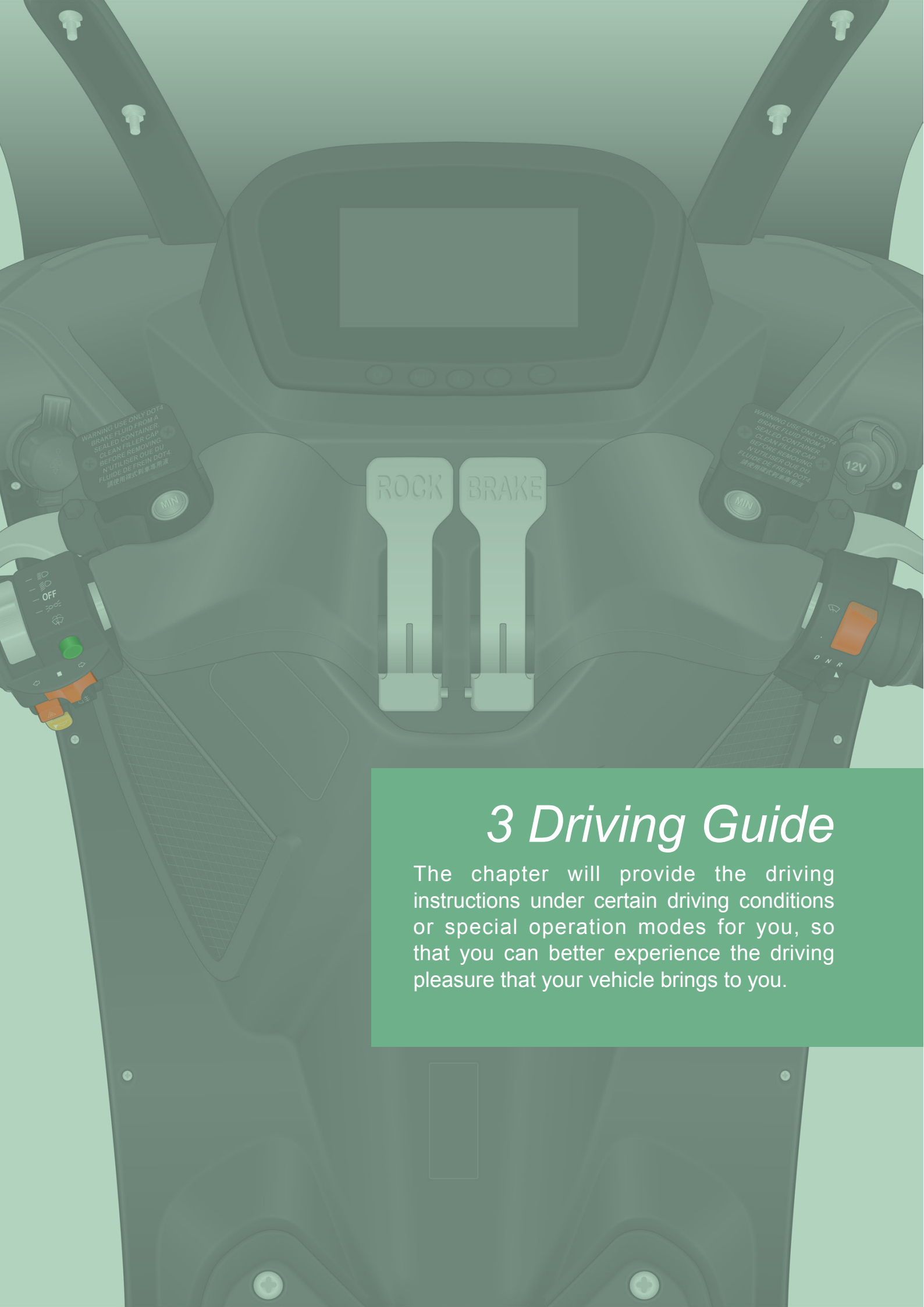

3 *Driving Guide*

The chapter will provide the driving instructions under certain driving conditions or special operation modes for you, so that you can better experience the driving pleasure that your vehicle brings to you.

Running-in period

In order to ensure the service life, the vehicle should be run in initial stage of using.

- ◆ After starting, do not run the motor at high speed, start gently, and do not accelerate quickly.
- ◆ Do not maintain the same speed for a long time. Regardless fast or slow speed, the electric motor should have various speeds in order to fully run in the electric motor.
- ◆ Emergency parking should be avoided as far as possible, especially within the first 300 km.
- ◆ Do not overload.

Preparation before driving

It is necessary to check the vehicle before driving. Check taking a few minutes will help you drive safely and enjoy driving.

- ◆ External inspection
 - » Inspect whether the tire is damaged or inflation pressure is appropriate, and whether foreign matter is embedded in the tread. Take corrective measures when necessary.
 - » Check whether the tire nut is loose.
 - » Make sure the rearview mirror and the assembled lamp clean and uncovered.
 - » After parking for a period of time, check whether there is any abnormal phenomenon such as water or other liquid leakage from the chassis.
 - » Check the chassis for foreign objects.
 - » Check whether the front and rear assembled lamp, the high level brake lamp and other lamps work properly or not.
- ◆ Internal inspection

- » Check whether basic hand tools are complete.
- » When starting the vehicle, check whether the indicator of combination instrument is normal.
- » Check whether brake fluid and windshield washer fluid are sufficient.

Directional handle

1 Handle

2 Handle / acceleration handle

◆ Handle

- » Hold the handle with both hands to guide the handle to swing towards left or right and realizes change of direction.

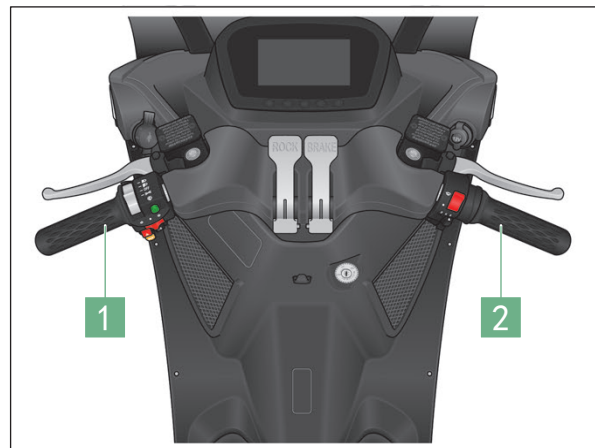

◆ Acceleration handle

- » The acceleration handle is used to control the speed. As shown in the figure, accelerate by turning the acceleration handle downward.
- » When the handle is released, the acceleration handle automatically returns and the speed decreases.

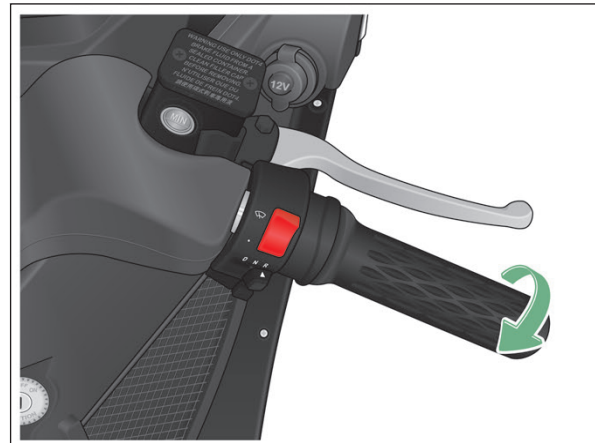

Horn

- ◆ The purpose of using horn is to give early warning in special road section or emergency situation, so as to ensure traffic safety. When the electric door lock is in the on position, press the horn switch and the horn will sound.

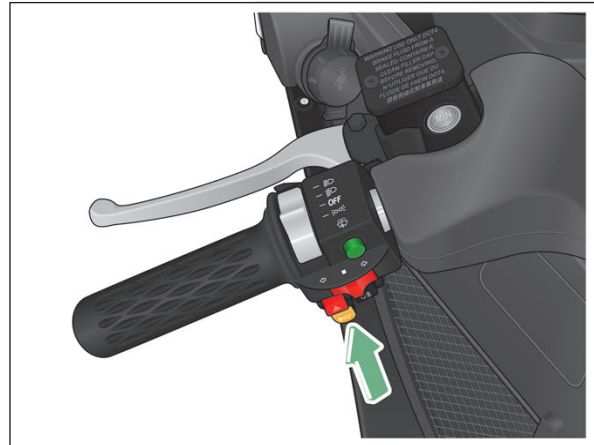

i Note

In case the vehicles in front wait in line or drive slowly, you should stop to wait or drive in sequence. Do not honk the horn to urge the front vehicles and pedestrians.

RAP Pedestrian alert

- ◆ The purpose of using warning sound is to give early warning in community road section or pedestrian condition, so as to prevent noise from disturbing residents. When the ignition switch is in the on position, press the button, and the reminder sound will sound.

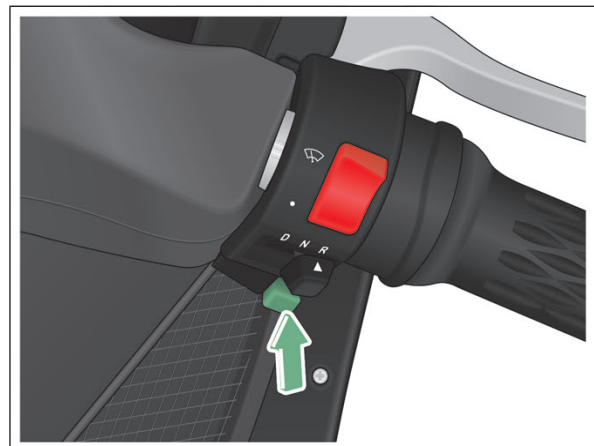

Ignition switch

Power gear

LOCK: The position where the key is inserted into and pulled out, stop the directional handle, and turn off the power supply system.

OFF: Stop the directional handle, and turn off the power supply system.

ON: After all the electrical devices on the vehicle are powered on, such as indicator lamps on the combination instrument, the vehicle will start self inspection.

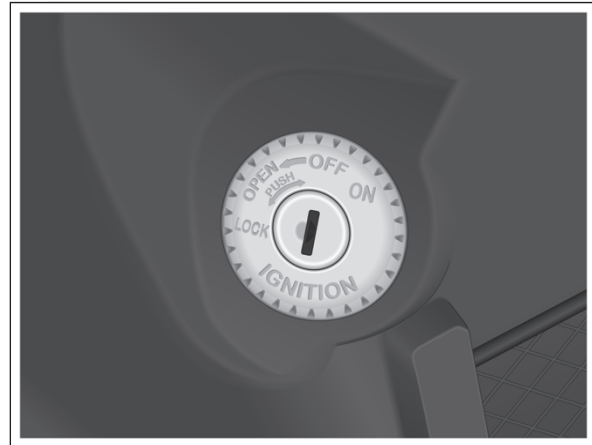

LOCK

When the key enters the "lock" from the "off", it is necessary to rotate counter-clock to the "lock" position while pressing the key. Turn directional handle to the left to the limit position and confirm the direction locked.



⚠ Warning

After the vehicle park completely, it needs to set the parking brake to prevent the vehicle from moving.

📘 Note

When the vehicle is not under use, do not keep the ignition switch in "ON" gear for a long time, so as to reduce power consumption.

Shifting system

- ◆ Toggle the shifting lever, the sequence from right to left is:

R: Reverse gear

N: Neutral

D: Forward gear

- ◆ "R" gear (reverse gear), which is used when backing up. Before entering "R" gear, make sure the vehicle has stopped completely. Turn off the swing system when backing up.
- ◆ "N" gear (neutral), which is used when parking.
- ◆ "D" gear (forward gear), this gear is held during normal driving.

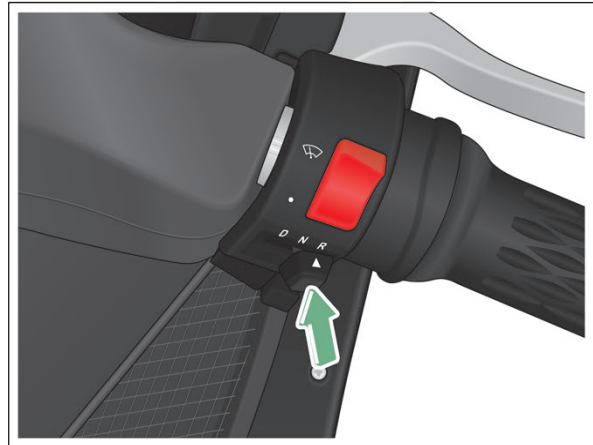

i Note

Only when the vehicle is fully stopped, change to another gear.

When you parking in "D" or "R" gear, just hold the handbrake. If you need to get off, you must change to "N" gear and set the parking brake.

Manual brake

1 Rear brake

2 Front brake

- ◆ The front brake controls the front wheel and the rear brake controls the rear wheel.
- ◆ Please hold front and rear brake at the same time when emergency braking is needed to avoid turning over.

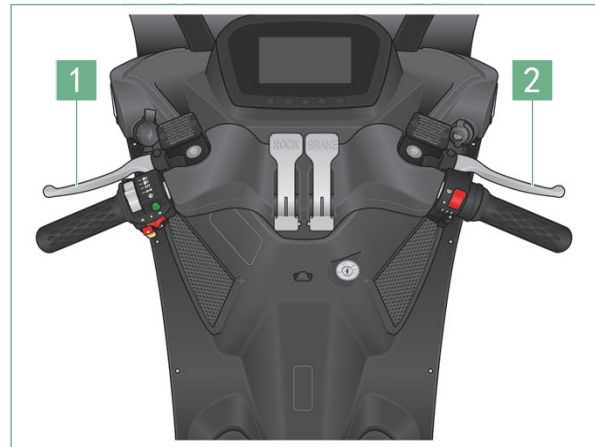

Parking brake

- ◆ Use parking brake when parking. If not, the vehicle may slide toward the bottom of the slope when parked on a slope.
- ◆ When setting the parking brake, it just needs to pull up the parking handle. In order to obtain a better holding force, hold the hand brake tightly until the parking handle is pulled up. When releasing the parking brake, hold the hand brake tightly and then put down the parking handle.



Starting

1. Hold the manual brake firmly to ensure that the shift lever is placed in "N" gear.
2. Rotate the ignition switch to the "ON" position to start vehicle.
3. Check whether the alarm lamp / indicator lamp inside the combination instrument is normal, and check the battery power.
4. Shift gear to "D", then instrument will display "D" and "READY".
5. Release the parking brake.
6. Release the brake.
7. Turn the acceleration handle and start driving.

Parking

Normal parking

1. Hold the brake tightly, park the vehicle, and push the shift lever to "N" gear.
2. Turn the ignition switch to the "OFF" position to power down the entire vehicle.
3. Set the parking brake and slowly release the brake.

Note

Observe whether there are pedestrians or obstacles nearby when parking to avoid accidents.

When parking, park vehicle in proper position to avoid hindering other vehicle.

Turn off all lights, check the indicator lights and text messages on the combination instrument, lock the direction handle, and confirm that the anti-theft system has been activated.

Carry valuables with you. Do not put them in the vehicle.

Emergency stop

If you have to stop in an emergency, you should choose a section without blind spots, turn on the danger warning lights immediately after stopping, prompt drivers nearby to pay attention to safety, and make sure the passengers get off as quickly as possible, and get off after ensuring that there are no vehicles travelling in the rear.

Driving essentials

- ◆ Drive slowly against the wind so that it is easy to control the vehicle.
- ◆ Do not drive into the curb and avoid driving on objects with high and sharp edges or other obstacles, otherwise the tires will be seriously damaged.
- ◆ Slow down when driving on rough roads. Otherwise, the impact will seriously damage the wheels.
- ◆ Slow down when driving on rough roads. Otherwise, the impact will seriously damage the wheels.
- ◆ Do not hold the hand brake continuously while driving, which will lead to dangerous overheating phenomenon, wear and waste of power.
- ◆ According to the different road conditions, it is recommended to carry some necessary emergency appliances or articles with you.

Drive in special weather

Drive in the rain

- ◆ In rainy day, the visibility is low and the road surface is slippery and it is prone to traffic accidents. Therefore, when traveling in rainy days, you should drive more carefully.
- ◆ When it begins to rain, as the road becomes slippery, the vehicle speed should be reduced.
- ◆ Clean the rearview mirror in time when raining to prevent blind spots caused by raindrops accumulated on the rearview mirror.
- ◆ On cloudy days, heavy rain and fog, and rainy days, the visibility is low, fog lamps and dipped headlights should be turned on in time.
- ◆ When driving in rainy days, emergency braking or turning the steering handle is prohibited. If it is necessary to reduce the speed, loosen the acceleration handle first and then gently grip the manual brake to control the speed and prevent rear-end collision.

- ◆ When there is too much rain or thunder and lightning, the vehicle is unable to continually driving, stop it at a position without water accumulation to prevent the vehicle from being soaked, and turn on the danger warning light to attract the attention of the rear vehicle.
- ◆ After wading in rainy days, wash the vehicle in time to prevent the acidic substances in the rain from corroding the paint surface of the vehicle body.

Drive in foggy weather

- ◆ The visibility of driving in fog is low. Please observe the precautions for driving in fog to ensure the safety of others and yourself.
- ◆ Before driving a vehicle in fog, the lighting device of the vehicle should be thoroughly checked. When driving, the fog lamp, the position lamp and the dipped headlights should be turned on to improve visibility, see clearly the vehicles ahead, pedestrians and road conditions, and to make it easy for others to see the location of their own vehicles. At the same time, it is forbidden to use full beam headlights when driving in fog.
- ◆ When driving in fog, it is forbidden to make emergency braking or turn directional handle suddenly. If it is necessary to reduce the speed, loosen the acceleration handle first and then gently grip the manual brake to control the speed and prevent rear-end collision.

Drive in hot weather

- ◆ Avoid exposing the vehicle to strong sunlight for a long time in hot weather, and avoid placing flammable substances (such as lighter, paper scraps, cloth toy, etc.) on the instrument panel and its vicinity.
- ◆ In order to drive the vehicle safely, the tire pressure should be checked regularly. As the air temperature and the temperature of the road surface rise, the tire pressure will easily rises and cause a tire burst when driving at high speed or driving a long distance.
- ◆ In hot weather, frequently check whether line of vehicle is short-circuited or aged, whether plugs are loose, whether the battery is in normal working condition, etc. to prevent spontaneous combustion.

Drive in cold weather

- ◆ Before driving in cold weather, the safety equipment of vehicle must be carefully checked: steering, braking, lamp, instrument, horn, wiper, etc. must be complete and effective.
- ◆ When the parking brake may freeze, it is recommended not to drive the vehicle immediately, you should wait until the parking brake thaws.
- ◆ In winter, road is slippery after snow. Keep the speed of vehicle stable and operation careful while drive. Do not suddenly accelerate, brake or make a turn. Slowly accelerate during driving, drive at medium and low speed.
- ◆ Be gentle and slow when starting and accelerating to prevent tire slippage and sideslip.



4 Maintenance

The chapter lists important contents about maintenance, adding fuel and fluid and tires so that to extend the service life of your vehicle.

Vehicle corrosion protection

Correct maintenance can prevent corrosion of vehicle.

The most common causes of vehicle corrosion are as follows:

- ◆ Saline - alkali, dust and moisture are accumulated in hard-to-reach areas under the vehicle.
- ◆ Lacerate the paint layer or bottom layer due to slight collision or due to stones and gravel.

To prevent vehicle corrosion, the following guidelines should be observed:

- ◆ Be diligent in washing the vehicle. Regular washing can keep the body clean, but in order to prevent corrosion, the following points should be observed:
 - » If you drive on saline-alkali road in winter or live by the sea, clean the vehicle at least once a month to reduce corrosion.
 - » The high pressure water gun is very effective for cleaning the chassis and wheel cover of vehicle. Since it is difficult to see all the mud and dirt in those places, special attention should be paid. Only wetting mud and debris and not removing them will cause greater harm to vehicle. Do not allow dust to clog the drain holes of the frame, otherwise the accumulated water in these parts will cause corrosion.
 - » After winter, clean the chassis thoroughly.
- ◆ Check the paint and decorations of vehicle.
 - » If any chips or cracks are found in the paint layer, they should be repaired immediately to prevent corrosion.
- ◆ Check the interior.
 - » Moisture and dust tend to accumulate in the interior and cause corrosion. Always check the interior to make sure it dry.
 - » When transporting chemicals, detergents, fertilizers, salts and other items, use appropriate containers for transportation. If spills or leaks are found, they must be cleaned immediately and kept dry.

- ◆ Park the vehicle in a good ventilated garage or a place with a roof. Do not park the vehicle in a damp and airtight garage.

Vehicle cleaning

Wash the vehicle by yourself

1. Flush the body, wheels and bottom of the vehicle with plenty of water from top to bottom to remove dirt and dust.
2. Use sponge or soft cloth to scrub the body.
3. For dirt that is difficult to remove, wash it with washing soap and rinse it with water.
4. Wipe the water off the body.

i Note

Check and confirm that the cover of vehicle charging port is closed before washing the vehicle.

Precautions for vehicle washing

- ◆ Aluminum wheels
 - » Immediately remove dirt from aluminum wheels with neutral detergent after being attached by filth. Do not use hard brushes or abrasive detergents.
 - » Do not use strong chemical cleaners, you should use the same neutral detergent and car wax as the paint surface.
 - » Do not use detergent for cleaning when the wheels are hot (such as after long distance driving in hot weather).
 - » After washing aluminum wheels with detergents, wash them

immediately.

◆ Combination lamp

- » Carefully clean the combination lamp to prevent scratching or crushing the mask.

i Note

When cleaning the combination lamp, do not use chemical solvents such as gasoline and alcohol to wipe the surface of the combination lamp, otherwise the combination lamp mask will crack.

 Environmental protection

The vehicle should be cleaned at the specially specified washing point to prevent the sewage containing oil from being directly discharged into the sewer. In some areas, except such washing points, it is forbidden to clean vehicles at any other place.

Brake fluid

- ◆ Use the brake fluid of the correct specification.
- ◆ When purchasing brake fluid, check the specifications indicated on the package, and the noted specifications must conform to the usage regulations of the vehicle.
- ◆ If the brake fluid level in the reservoir is above the "MIN" (minimum) scale, the fluid level is normal.
- ◆ If the liquid level is lower than the "MIN" scale, you need to add brake fluid until it is above the "min" scale.

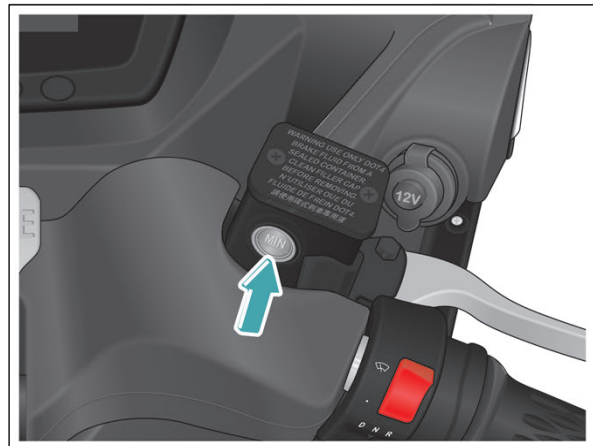

Warning

Please put brake fluid out of children's reach.
 Do not spray brake fluid on the decoration, if the brake fluid is sprayed on the decoration, please clean it with water immediately.
 The package of brake fluid is marked with the brake fluid specification, in any case the brake fluid with the correct specification must be used.

- ♻️ **Environmental protection**
 Discarded brake fluid must be treated in accordance with environmental laws and regulations. Do not dump it directly in garbage dumps, sewers or on the ground.

Maintenance

Cleaning solution

- ◆ Check the cleaning solution in the washing kettle. If there is too little quantity, add cleaning solution or a mixture of cleaning solution and water. Pure water can hardly wash the windshield completely.

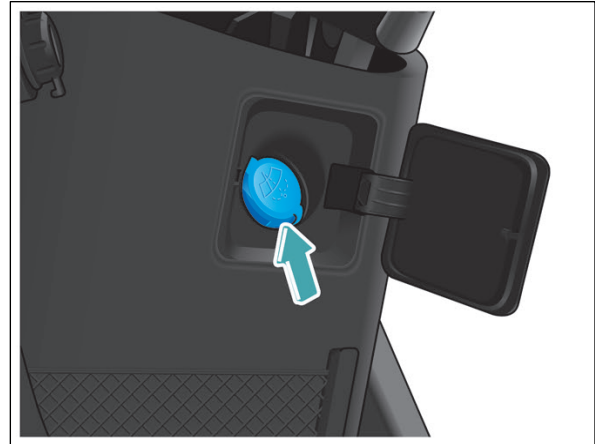

⚠ Warning

Do not add any additives to windshield cleaning solution. Otherwise, oil stains or other sundries will be attached on the windshield when cleaning, which will seriously affects the vision ahead and easily leads to accidents.

ℹ Note

Do not replace cleaning solution with soapy water or other antifreeze, otherwise it may make markings on the paint surface of the vehicle.
Do not mix windshield detergent with other cleaning agents. Otherwise, it will cause the decomposition of detergent and block the nozzle of windshield washer

Tire

- ◆ In order to drive the vehicle safely, the model and size of the tire must be suitable for the type of your vehicle and the tires should have a tire tread in good condition and standard tire pressure.
- ◆ The following contents will describe in detail how to check the tire pressure, tire damage and wear, and operation methods of tire maintenance.

Warning

Using the tires with excessive wear, insufficient tire pressure or excessive tire pressure will cause accidents and cause personal injuries. All instructions on tire inflation and maintenance in this manual must be followed.

Inflate

- ◆ Keeping the tire inflated properly can provide the best combination of maneuverability, tread service life and driving comfort.
- ◆ Driving on under-inflated tires will cause uneven wear of tire, affect operation and power consumption, and even cause air leakage due to overheating.
- ◆ Using over inflated tires will reduce the comfort, and it will also be more likely to be damaged due to uneven road surface, and there will be a high risk of tire burst in serious cases, which will seriously threaten the driving safety. At the same time, it also causes uneven tire wear and affects tire service life.
- ◆ When measuring the tire pressure, the tire should be in a cold state, which means that it should be measured after at least three hours of stopping.
- ◆ If the tire pressure is checked when the tire is hot, the pressure reading will be higher than that when the tire is cold. This kind of reading is normal. Do not deflate to reach the specified cold tire pressure reading, otherwise the insufficiency of tire pressure will be caused.

i Note

The recommended tire pressure label plate (affixed on the inner panel beating of the charging port cover) indicates the recommended tire pressure in cold state.

Check

- ◆ When checking the inflation state of tires, injury, foreign objects piercing and abrasion shall also checked. If any of the following conditions are found, the tire should be replaced.
 - » Damage and protrusion on the tread or the side.
 - » Scratch, crack or fracture on the side of the tire, or the cord fabric or cord thread is exposed.
 - » Excessive wear of tread.
- ◆ The wear mark is cast inside the tread of the tires. When the wear mark is exposed due to the wear of tread, the adhesion of the tire on the slippery road will become smaller, and the tire should be replaced at this time.



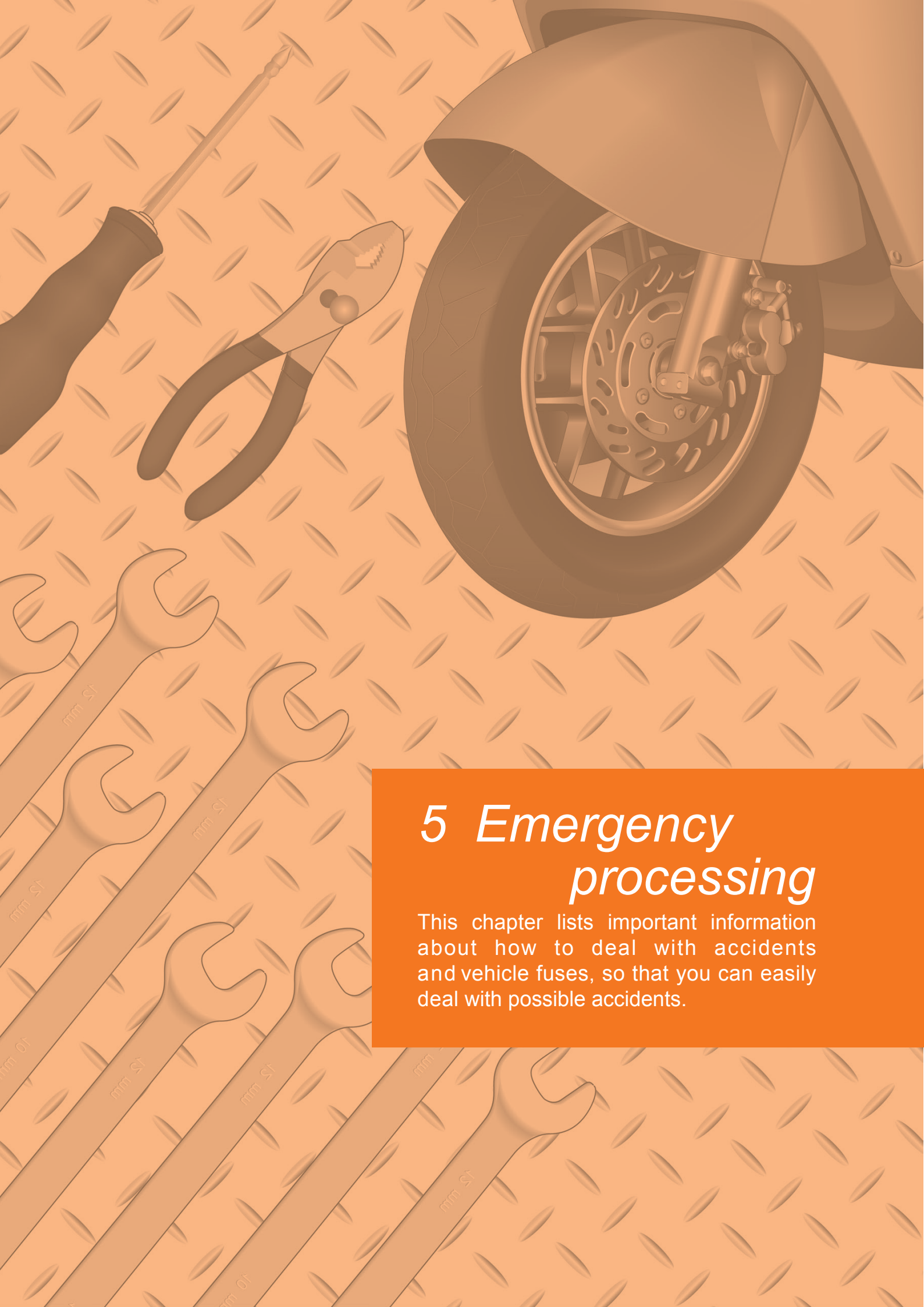

5 *Emergency processing*

This chapter lists important information about how to deal with accidents and vehicle fuses, so that you can easily deal with possible accidents.

Hazard warning lamp

- ◆ If the vehicle breaks down or traffic accident occurs, use the hazard warning lamp. After pressing the hazard warning lamp switch, all turn signals and turn indicators will flash. Press the hazard warning lamp switch again, they will go out.

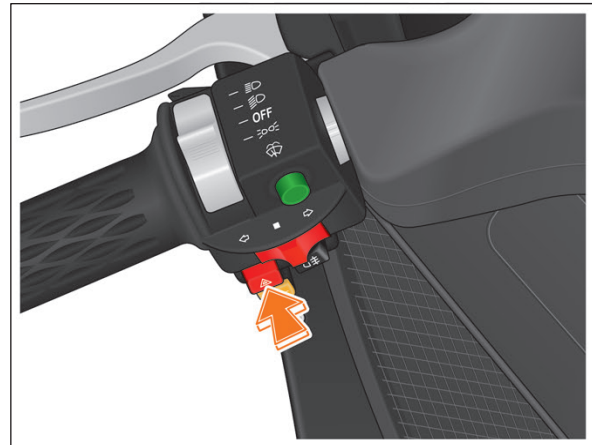

Note

If the hazard warning light does not work, place a warning triangle in the rear of the vehicle according to regulations, or take other methods to attract the attention of other driving vehicles. The methods used must comply with relevant traffic laws and regulations.

Triangular warning board

- ◆ The triangular warning board is placed in the cargo box and is used to warn the rear vehicles to avoid the danger of collision with the vehicles parked or maintained by the front due to too fast speed or delayed braking.
- ◆ Usage of triangular warning board:



- » Take the warning triangle out of the box.
- » The combined triangle warning board is a closed triangle.
- » Release the support bracket of the triangular warning board, the active state is shown in the figure.

i Note

When parking and maintaining vehicle on public road, please bear it in mind that the red side of the warning triangle faces the driving direction of the vehicle and place in the position where is 50 to 150m away from rear of the vehicle to warn the vehicles behind so as to avoid danger. After the repair, please take back the warning triangle for the next use.

Reflective vest

- ◆ The reflective vest provided from the factory are placed in the seat storage box. If you need to get off during driving, especially at night, please wear the reflective vests before getting off so that the rear vehicles can find as soon as possible.



i Note

- ◆ Please keep the reflective vests in the vehicle all the time. If the reflective vests are damaged or defaced seriously (which will affect the reflective effect), it is recommended that you replace the reflective vest in time.

Basic hand tools

- ◆ The basic hand tools are placed in the seat storage box. They mainly include maintenance tools ,fire extinguishers and reflective vest.

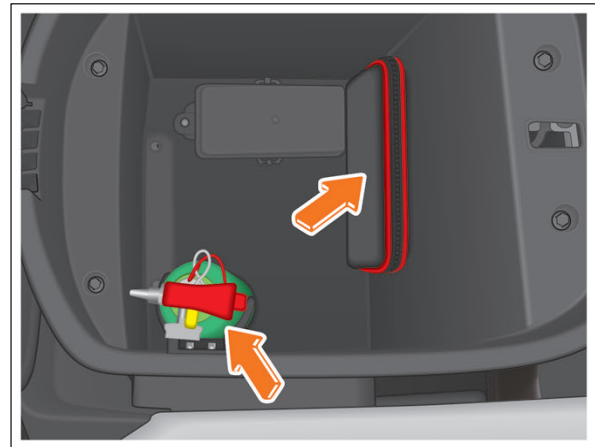

- 1 Allen wrench GB/T5356-6
- 2 Allen wrench GB/T5356-8
- 3 Non-adjustable wrench 8~10mm
- 4 Non-adjustable wrench 10~12mm
- 5 Phillips screwdriver / slotted screwdriver

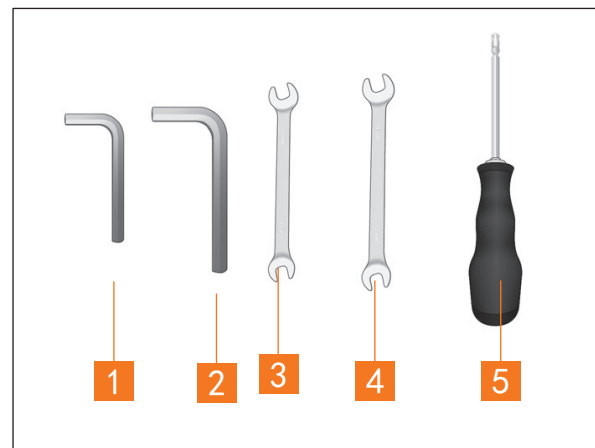

i Note

In order to deal with various emergency situations, you should be familiar with the use and placement of fire extinguishers and tools.

Unable to start

- ◆ If the correct starting procedure is followed, but the vehicle is still not started, please consider the following reasons:
 - » The power battery has run out of power.
 - » The drive motor has failed.
- ◆ If the powertrain has no power output during driving, the following operations shall be performed:
 - » Move the car to safety.
 - » Turn on the hazard warning light.
 - » Try restarting the vehicle.

Note

If the vehicle cannot be restarted, it needs to be adjusted or repaired. It is recommended to contact RAP's authorized service station.

Instrument failure

- ◆ When blue screen and stuck phenomenon occur occasionally, restart ignition switch to eliminate blue screen and stuck phenomenon. If it cannot be eliminated, it is recommended to contact RAP authorized service station.

If the vehicle is trapped

- ◆ If the vehicle is trapped in sand, mud or snow, please carry out the following operations:
 - » Turn the ignition switch to "OFF", pull up the parking brake handle.
 - » Clean up mud, snow or sand trapped around the tires.
 - » Place wooden blocks, stones or other materials to help strengthen friction of tire.
 - » Restart the vehicle, accelerate it carefully and get it out of the pit.
- ◆ If you can't get the vehicle out by using the above method, you need to try pushing the vehicle forward and backward to get it out of the pit.

Note

When pushing the vehicle, pay attention to the situation around. Do not move forward or backward suddenly after the vehicle getting out of pit, to avoid causing injury or damage to people or objects around.

Vehicle traction

- ◆ If traction is needed, it should be carried out by the corresponding RAP's authorized service station or a professional trailer company.
- ◆ It is recommended to give priority to the platform trailer. If the wheel and axle of are in good condition, the wheels lifting trailer can also be used to tow the front of the vehicle.

- ◆ Platform trailer

- » This is the best way for vehicle traction

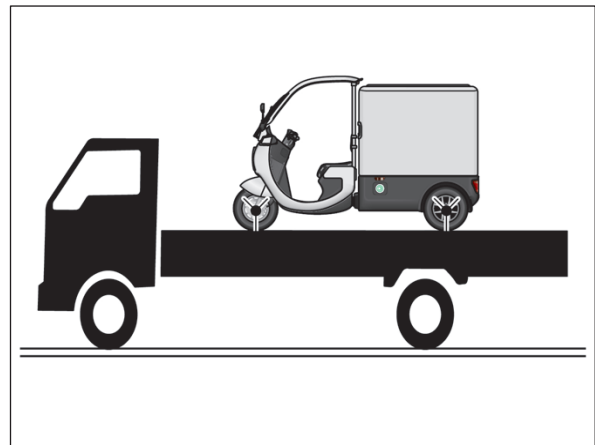

- ◆ Wheel lifting trailer

- » When towing the vehicle from the front of vehicle using a wheel lifting trailer, it is recommended to use a towing trolley under the rear wheels. If not use the towing trolley, it needs to release the parking brake.

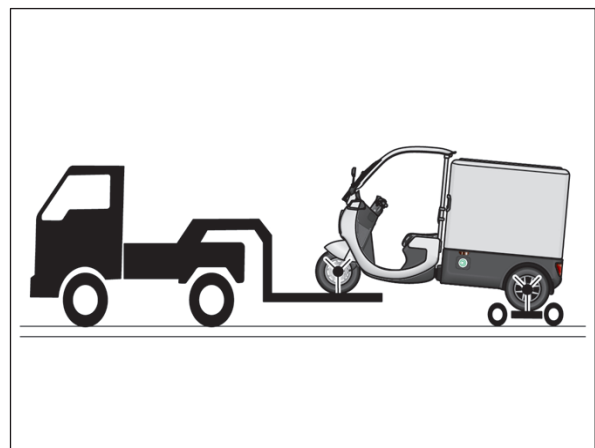

Tire burst

- ◆ When a tire burst occurs during driving, stop the vehicle according to the following tips. Replace tires as needed after parking.



Warning

When you are aware of tire burst during driving, hold the steering handle with both hands and strive to control the steering handle in order to not make rotate on its own so that the vehicle can run straightly in the original direction.

Do not hold the handbrake seriously, which may cause the vehicle to lose the barycentre and lose control or roll over.

Hold the hand brake gently, slow down and park the vehicle by the side of the road.

Turn on the hazard alarm lamp timely, and place the warning triangle behind the vehicle as stipulated to warn other road users about safety.

Preventive measures for tire burst

- ◆ Regularly check tires to eliminate the hidden danger of tire burst.
- ◆ Usually remove stones or foreign objects from tread grooves to avoid deformation of tire crown. Check the tire sidewall for scratches, stabs, or excessive wear.
- ◆ All tires should be used within their service life, and tires that exceed their service life or have been seriously worn should be replaced in time.

Fire emergency processing plan

- ◆ After the vehicle is on fire, please pull over at the first time, turn off all power supply systems of the vehicle, check the fire area, use fire extinguishers and quickly organize fire suppression, correctly judge the fire, abandon the vehicle and leave and keep a safe distance if necessary.
- 1. Check that the fire position. Do not touch the fire source with your hands to avoid scalding, and do not extinguish the fire with conductive objects such as water sources to prevent electric shock or secondary damage to the system inside the vehicle. Use fire extinguishers as much as possible to aim at the bottom of the flames and the gaps of vehicle, or use soil sand on the roadside to cover up the fire source so as to isolate the ignition point from the air.
- 2. Spray the bottom of the ignition point with fire extinguisher until the fire extinguisher is used up completely, abandon the vehicle and leave and keep a safe distance if necessary.

Warning

There is a possibility that the battery explodes after the vehicle ignites. If the fire becomes too fierce to control, please leave the scene decisively and call the police.

It is recommended to contact RAP's authorized service station for handling after putting out the fire. Do not rashly contact the vehicle after the fire accident to prevent electric shock, burns other accidents.

In order to prevent vehicle fires in a timely and effective manner, the following precautions should be observed in use:

- ◆ Do not store inflammable and explosive articles in the vehicle.
 - » In summer, if store lighter, cleaning agent, perfume and other inflammable and explosive articles in the vehicle, it will easily cause fire and even explosion.
- ◆ It is forbidden to refit vehicle circuits and install electrical components.

- » Install other electrical appliances will cause overload of circuit and the wiring harness will easily heat up and cause fire.
- » It is strictly prohibited to replace fuses with the fuses or other wires that exceed the rated specifications.
- ◆ It is recommended to conduct regular inspections at RAP's authorized service station.
 - » Regularly check whether there is oil leakage, timely clean up the oil scale and oil stain on the motor, so as to prevent the oil scale and oil stain from volatilizing under high temperature and causing fire.
 - » For the whole circuits of vehicle, regular inspection should also be carried out, including connectors, insulation and fixed positions of electrical components and wire harnesses, etc., if any problems are found, please deal with in a timely manner.
- ◆ The vehicle is equipped with the portable fire extinguisher, and you need to know how to use them.
 - » In order to ensure the safety of the vehicle, the vehicle is equipped with fire extinguisher, which needs to be checked and replaced regularly. At the same time, we should be familiar with the use of fire extinguishers, so as to be prepared for emergencies, and avoid being helpless in case of accidents.
- ◆ Precautions for driving.
 - » During parking, especially in summer, check whether there are flammable substances under the vehicle, such as hay, dead twigs and leaves or straws. If any, it is likely to cause fire.
 - » During driving, vehicle should also try to avoid the driving on the road where combustible materials such as dry leaves, straw and weeds are piled up, or stop in time to check whether combustible materials are hung on the bottom of the vehicle after passing through such roads. When parking, avoid parking on the place where is exposed to the hot sun as far as possible.

High pressure component

- ◆ Do not expose the battery under any circumstances. In rainy and snowy weather, if the battery is exposed due to the failure, use waterproof cloth and other equipment to cover up the battery quickly to prevent the battery from getting wet, and contact the service center to ask the professional maintenance personnel for repair.
- ◆ In case of water intrusion into the battery, power off the vehicle immediately, contact the service center quickly, and ask the professional maintenance personnel to handle the battery. After repair, and the professional maintenance personnel tell you that it can be used normally, you can restart it. It is strictly prohibited to start the vehicle after water intrusion into the battery.
- ◆ Users and relevant operators must use the charging device provided by RAP when charging and maintaining the vehicle. When charging, please strictly follow the prescribed procedures and operation requirements, and the correct and standardized operations can better ensure the safety of the battery during use.
- ◆ Regularly carry out maintenance and inspection to the battery and charging system. If any problems are found, repair or replace the battery and charging system in time to ensure that the battery and charging system are always in a safe working state.
- ◆ Do not place the vehicle in an extreme environment for a long time: high temperature, collision, etc. are all important causes of battery explosion. Strive to keep the battery in a stable environment away from high temperature.
- ◆ It is strictly forbidden for people to refit the vehicle without permission. Illegal Refitting will cause a series of damage to the harness inside the vehicle, such as short circuit, which can easily lead to accidents and increase safety risks.

Fuse

- ◆ All circuits on your vehicle are equipped with fuses to prevent the wiring harness from damaging caused by short circuit or overload. These fuses are installed in the fuse box in the seat storage box.
- ◆ Open the seat, press the lock catch of fuse box and remove the fuse box cover to check or replace the fuse.

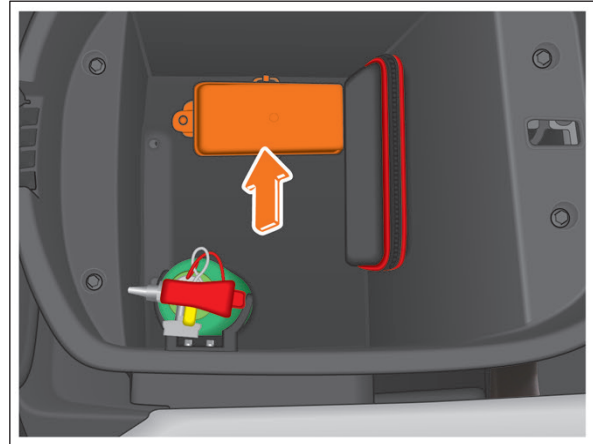

⚠ Warning

If you need to replace the fuse, please select a replacement fuse that the amperage matches the circuit. Do not replace the fuse with a fuse higher or lower than the rated amperage or any other object, otherwise it will cause serious damage to the electrical system and may cause fire.

Sticker of fuse box

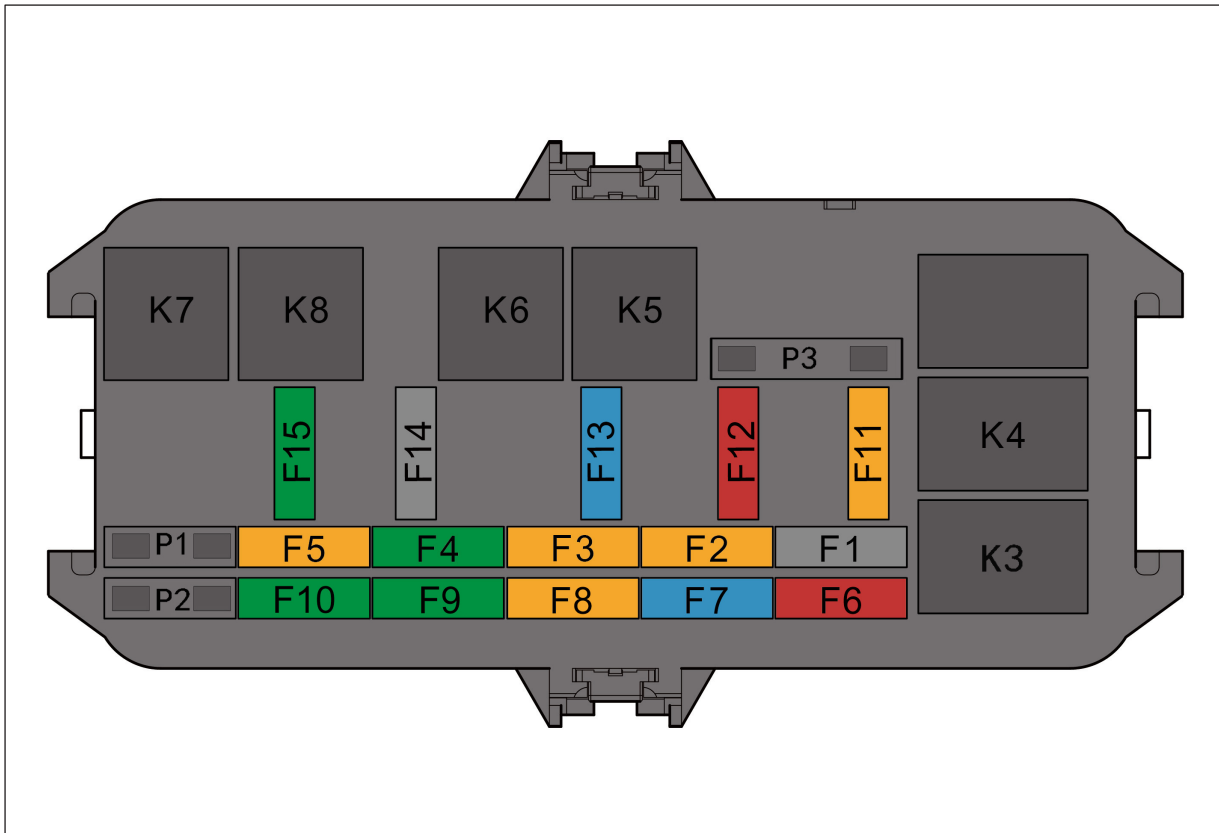

No.	Amperage (A)	Protected components or electrical device
F1	25	12V power supply
F2	5	USB
F3	5	Terminal
F4	30	DC
F5	5	Simulate
F6	10	Lighting
F7	15	Washing
F8	5	Instrument
F9	30	Key ON
F10	30	Battery check port fuse

No.	Amperage (A)	Protected components or electrical device
F11	5	Standby
F12	10	Standby
F13	15	Standby
F14	25	Standby
F15	30	Standby
P1		Power battery diagnosis upgrade port
P2		Vehicle diagnostic port
P3	-	Battery check port
K3	-	Parking relay
K4	-	Electric door lock control relay
K5	-	Electronic control signal relay
K6	-	Brake
K7	-	Forward
K8	-	Back

6 *Technical data*

This chapter includes technical parameters, stickers and other technical data, which can help you when necessary.

Vehicle parameters

Product model name		Bange	
		Normal version	Fast charge version
Outline dimension (mm)	Length of entire vehicle	2920	
	Width of entire vehicle	980	
	Height of entire vehicle	1850	
Wheelbase (mm)		2240	
Track width (mm)		820	
Top speed(km/h)		45	
Reverse speed (km/h)		≤5	
Full mass (kg)		685	
Maximum climb capacity (%)		20	
Minimum turn radius (m)		3.5	
Rated power (kW)		3.7	
Swing angle (°)		±18	
Ground clearance (half load)(mm)		150	
Type of tire	Type of front tires	110/90-12	
	Type of Rear tires	110/90-12(Option)	
	Type of Rear tires	135/70R12(Option)	

Product model name		Bange	
		Normal version	Fast charge version
Tire pressure (kPa)	Front tire	250	
	Rear tire	250	
Battery nominal voltage (V)		72	
Battery usable energy (kWh)		6.99	
Slow charging time (h)	20% - 80%	/	< 1.5
	0% - 100%	< 8	< 3.5
Motor type		Ac asynchronous motor	
Layered cargo box	Outline size(mm)	1300 × 940 × 1250	
	Volume(m ³)	1.4	
	Curb mass(Kg)	260	
	Loading mass(Kg)	250	
Cargo box (Larger)	Outline size(mm)	1300 × 940 × 1250	
	Volume(m ³)	1.4	
	Curb mass(Kg)	260	
	Loading mass(Kg)	250	

Product model name		Bange	
		Normal version	Fast charge version
Refrigerated box	Outline size(mm)	1380 × 940 × 1000	
	Volume(m ³)	0.9	
	Curb mass(Kg)	230	
	Loading mass(Kg)	150	
Insulation box	Outline size(mm)	1380 × 940 × 1000	
	Volume(m ³)	0.9	
	Curb mass(Kg)	230	
	Loading mass(Kg)	190	
Pickup	Outline size(mm)	1400 × 940 × 590	
	Side board height	300	
	Curb mass(Kg)	250	
	Loading mass(Kg)	260	
Decorative pickup	Outline size(mm)	1400 × 940 × 260	
	Side board height	300	
	Curb mass(Kg)	240	
	Loading mass(Kg)	270	

Product model name		Bange	
		Normal version	Fast charge version
Front brake	Front brake	Double plate	
	Rear brake	Single plate	
Suspension system	Front fork	Telescopic	
	Rear suspension	Swing - arm double double - acting damper	
Transmission system	Driving model	Central motor bridge driver	
Driving model		Rear - wheel drive	
Rotation angle of elevating handle (°)		40	

Note: 1.Actual power consumption is related to vehicle conditions, road conditions, driving habits and other factors.
2.Width of the body does not include rearview mirror

Vehicle identification code

- ◆ The vehicle identification code is under the front lower guard plate of the body.

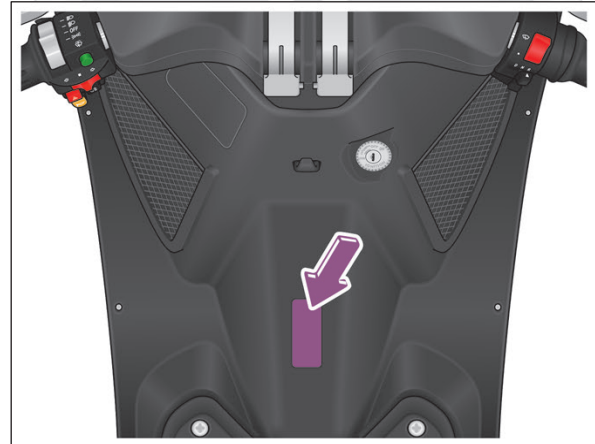

Nameplate of entire vehicle

- ◆ The nameplate of the entire vehicle is on the bottom panel beating of the frame. The nameplate of entire vehicle contains the following information:

- » Manufacturer's name
- » Vehicle model
- » Vehicle certificate number
- » Vehicle identification code
- » Motor power
- » Top speed
- » Full mass

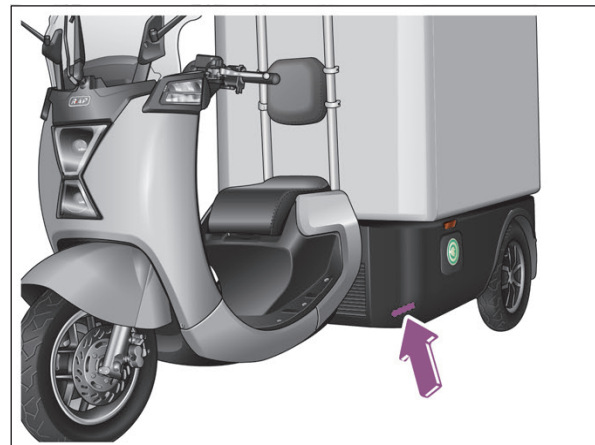

Motor model and serial number

- ◆ The model and serial number of drive motor are on the nameplate of the drive motor housing.

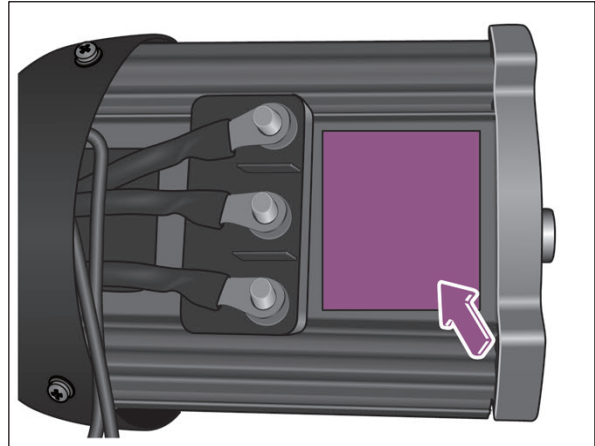

- ◆ The model and serial number of drive motor are marked on the drive motor housing.

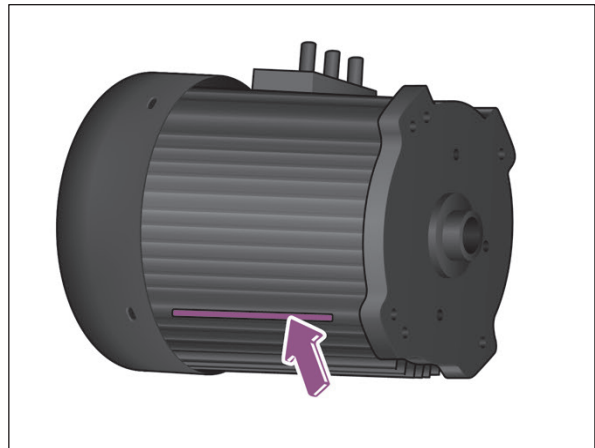

Warning sticker

- ◆ The tire pressure indicator is pasted on the interior of charging flap.

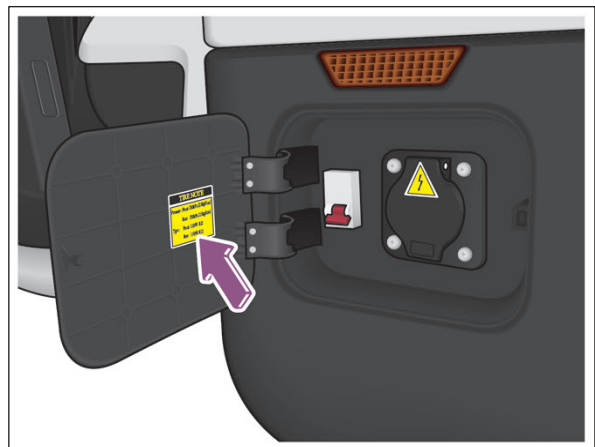

- ◆ Brake fluid addition warning is on the cover the brake fluid addition port.

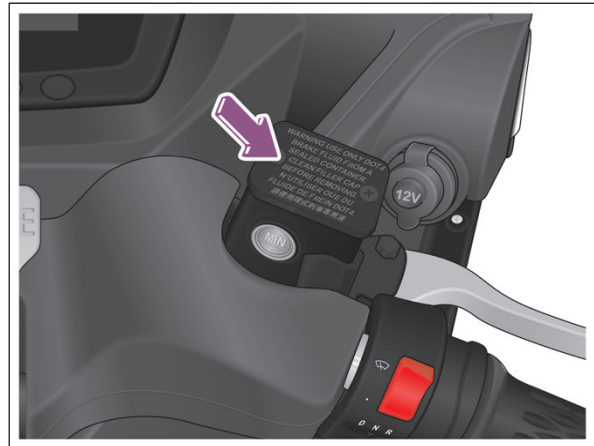

- ◆ Washing liquid addition warning is in the interior of the cover plate of washing liquid.

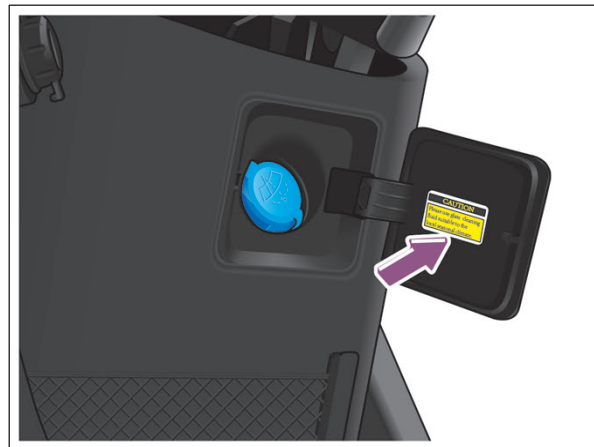

A

Anti-theft system
(Keys and doors)25

B

Backrest(Seat).....33
Basic hand tools
(Important information)64
Brake fluid
(Additional maintenance).....57

C

Charging pile single-phase
AC charging
(Charging method).....10
Charging precautions
(Charging instructions)6
Cleaning solution
(Additional maintenance).....58
Clock display
(Instrumentation)19
Combination meter
indicator/ warning light
(Instrumentation)19
Combination meter view
(Instrumentation)16
Current display

(Instrumentation)17

D

Directional handle
(Preparation).....43
Drive in special weather
(Driving and environment)50
Driving computer
(Instrumentation)21
Driving essentials
(Driving and environment)50

F

File bag(Storage device)38
Fire emergency processing
Plan(Contingency processing).....68
Fuse(Contingency processing)....71

G

Gear display(Instrumentation)18

H

Hazard warning lamp
(Important information)62
High pressure component
(Contingency processing).....70
Horn(Preparation).....44

Household single-phase
AC charging(Charging method).....9

I

If the vehicle is trapped
(Contingency processing).....65
Ignition switch(Start driving)45

L

Light distribution view
(Wiper and light)28
Light switch(Wiper and light)30

M

Manual brake(Start driving)47
Mechanical key
(Keys and doors)25
Mileage display
(Instrumentation)18
Motor model and serial number
(Prompting message)80

N

Nameplate of entire vehicle
(Prompting message)79

O

On-board charging device
(Charging instructions)7

P

Parking brake(Start driving).....47
Parking(Starting vehicle)48
Power battery(Battery).....12
Preparation before driving
(Preparation).....42
12V power supply
(Other devices).....40

R

RAP sound simulation
(Preparation).....44
Rearview mirror(Driving aid).....34
Rearview radar(Driving aid).....34
Reflective vest
(Important information)63
Reversing image(Driving aid)36
Run-in period(Preparation).....42

S

Seat cushion(Seat).....33
Shifting system(Start driving).....46

SOC electricity meter
(Instrumentation)17

Speedometer(Instrumentation)....17

Starting(Starting vehicle)48

Storage box under the seat
(Storage device)38

Storage hook
(Other devices).....39

Swing system(Driving aid).....37

T

Tachometer(Instrumentation).....17

Tire burst
(Contingency processing).....67

Tire(Additional maintenance).....59

Triangular warning board
(Important information)62

U

Unable to start
(Contingency processing).....65

USB interface
(Other devices).....39

V

Voltage display
(Instrumentation)17

Vehicle corrosion protection
(Daily maintenance).....54

Vehicle cleaning
(Daily maintenance).....55

Vehicle identification code
(Prompting message)79

Vehicle parameters
(Information)76

Vehicle traction
(Contingency processing).....66

W

Warning sticker
(Prompting message)80

Wiper switch
(Wiper and light)27

